

BU



**User's Manual**



2009

**CONTENTS**

1. Functions	p. 3
2. Circuit symbols	p. 3
3. Package	p. 4
4. Specifications	p. 4
5. Operating conditions	p. 4
6. Safety requirements	p. 4
7. Description and structure	p. 5
8. Installation	p. 6
9. Connecting to supply network	p. 7
10. Configuring and set-up	p. 9
11. Storage precautions	p. 11
12. Manufacturer's warranty	p. 11
13. Acceptance certificate	p. 12
14. Warranty card	p. 12

The device is multifunctional fan control unit (further BU).

#### Functions

BU is used to operate mode of fans located in accommodation space (kitchen, bathroom, bedroom...).

BU can include depending on model (tab. 1) automatic control function based on use of moisture sensor (hygrostat), lighting sensor (photo switch), moving sensor, timer and hand control of inner and outer switch.

Also BU provides cyclic turning the power on and off. Using switches you can set any function mode fit to situation.

For example, in the toilet you can use lighting sensor and timer. So the fan will turn on when somebody comes in and will keep working for 10 (for example) minutes.

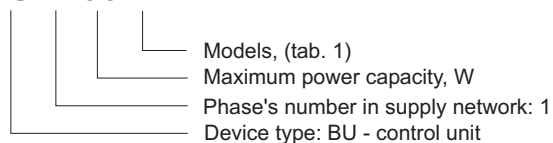

## VENTS BU-1-60 X



#### Circuit symbols

**Table 1.** Models

model	options				
	switch	timer	lighting sensor	moisture sensor	moving sensor
VENTS BU-1-60 TF		•	•		
VENTS BU-1-60 THF		•	•	•	
VENTS BU-1-60 THPF		•	•	•	•
VENTS BU-1-60	•	•	•	•	•

<b>Package</b>	Package includes: - control unit 1pc; - user's manual 1 pc; - package box 1pc.
<b>Specifications</b>	Voltage 220-240 V, 50 Hz Maximum capacity 60 W Loading type inductive, active Protection power IP34 Dimensions, less than 151x46x27 mm
<b>Operating conditions</b>	Environment temperature 0°C ... +40°C Adjust range of moisture threshold 40-100 %.
<b>Safety requirements</b>	BU installing must be carried by an electrician specialist according to existing regulations.
 <b>CAUTION</b>	The ambient air must include no explosive and corrosive impurities.
 <b>NOT ALLOWED</b>	Using BU out of temperature range and in the rooms with aggressive impurities in the air.
 <b>CAUTION</b>	BU scheme is under voltage. Install only when voltage is off.

**Description  
and structure**

To reach the best design and effect BU should be installed right under the fan (pic. 1)

BU front panel includes:

- ⊙ moving sensor (option)
- ✧ lighting sensor

BU function modes are indicated by:

- \* red LED the fan is on;
- ✧ red LED moving sensor actuation (option);
- yellow LED lighting sensor actuation;
- ♠ green LED moisture sensor actuation (option).

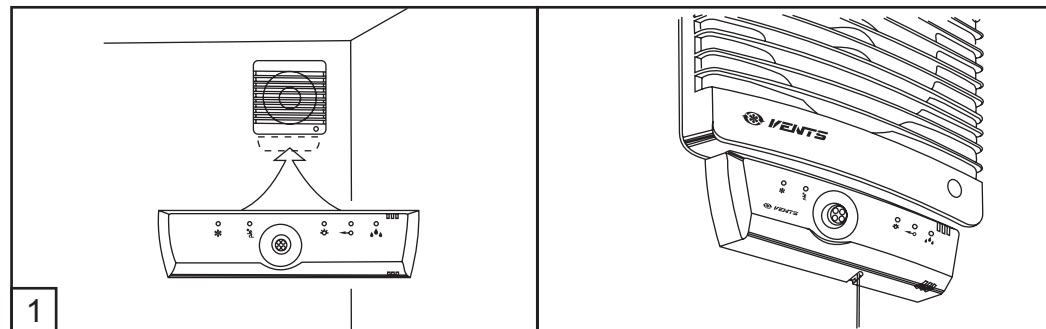

**CAUTION**

Moving sensor operative range is 5 m and viewing angle is 130°(pic. 2).

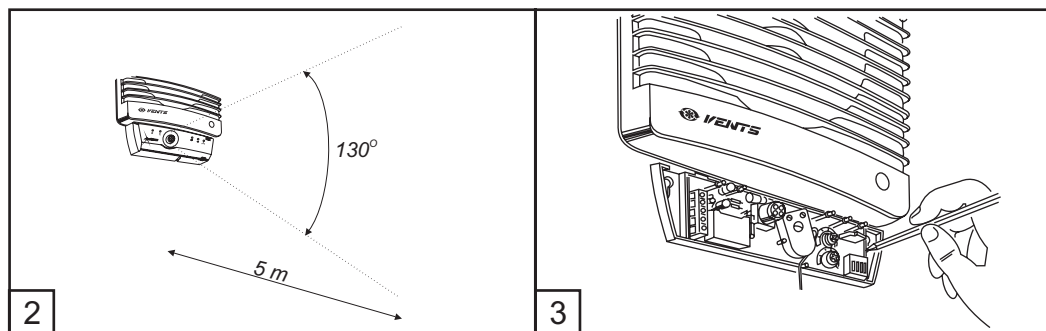
**Installation**

BU installation requires:

- to take off BU front panel;
- to choose BU installation position and to outline it with the pencil (pic. 3);
- to make holes for dowels;
- to screw screws into the dowels;
- to mount BU back panel on screws and to move it upwards;
- to fix it;
- to connect BU to supply network (read about connecting to supply network)
- to make its configuring and set-up (read about configuring and set-up);
- to mount BU front panel and fix it.

**CAUTION**

BU mounting holes' design requires BU to be moved upwards during the installing and then fixed.

1. Connecting to supply network must be provided with the switch with the clearance between the contact not less than 3 mm mounted into the fixed wiring.

**Connecting to supply network**

BU connecting depends on its model. Explore connecting scheme (pic. 5a for model BU-1-60 and pic. 5b for models BU-1-60 TF, BU-1-60 THF, BU-1-60 THPF). Install only when the power is off (pic. 4). Installation should be done carefully to keep BU's electronics safe.

**CAUTION**

2. Connect BU supply wire to outer automatic switch.

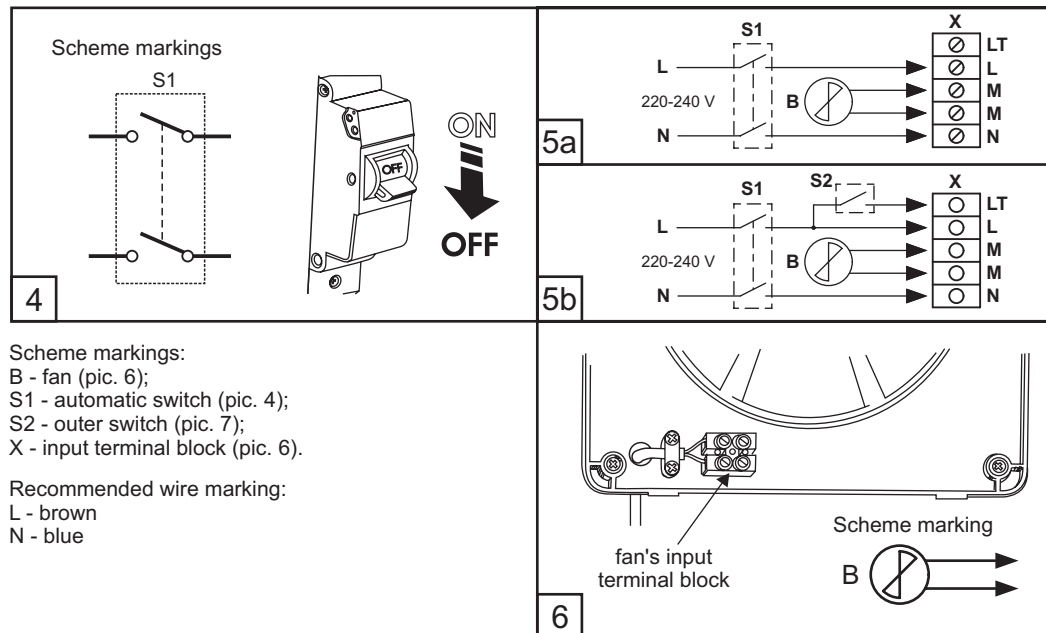

Scheme markings:  
 B - fan (pic. 6);  
 S1 - automatic switch (pic. 4);  
 S2 - outer switch (pic. 7);  
 X - input terminal block (pic. 6).

Recommended wire marking:  
 L - brown  
 N - blue

3. Open the fan. Connect supply wire to the input terminal block. Close the fan.

**CAUTION**

Fan's connecting depends on its model.  
We recommend you to explore its passport before connecting.

4. Connect BU input terminal block (pic. 8) according to connection scheme (pic. 5a or 5b).

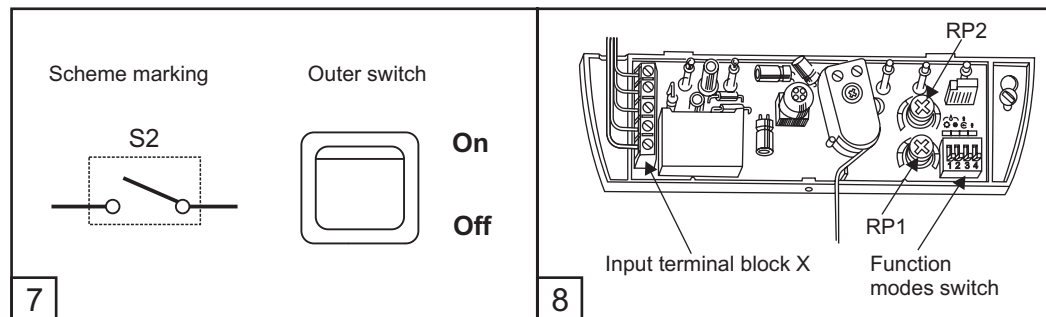

5. Configure BU for your purposes (read about configuring and set-up).

6. Put on the front panel and fix it.

7. Turn BU on by setting the switch into ON position (pic. 9).

If everything is done correctly, the fan starts working in the set mode.

If the fan fails to work, please carry out its diagnostics using this manual.

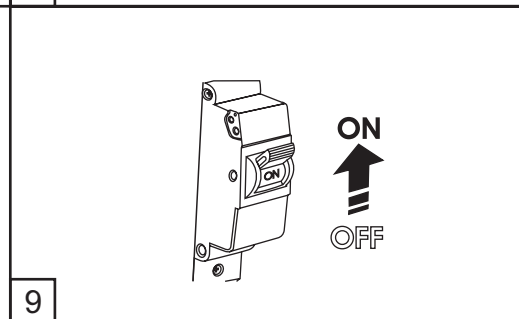



To configure BU settings:

1. Choose one of the five modes using the switch (pic. 8).

**Configuring  
and set-up**

Function modes' details.

### 1.1 Hygrostat (option)

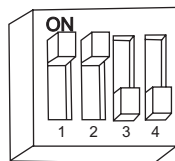

The fan turns on when moisture level is exceeded. Moisture level is set with RP1 regulator (pic. 8) according to table 3. Green LED indicates moisture level exceeding and turns the fan on. After moisture level drops, the fan will be working for the time set with RP2 regulator according to table 2. The mode is activated by setting switches 1 and 2 into ON position.

### 1.2 Photo switch

Turning the fan on and off depending on illumination (two modes are available):

#### Photo switch (dark)

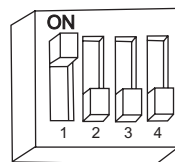

The fan is turned on in 5 seconds after the light in the room turns OFF. Fan's working time is set with the RP2 regulator according to the table 2. Operating threshold is set with RP1 regulator. Yellow LED indicates illumination threshold exceeding. The mode is activated by setting switch 1 into ON position.

#### Photo switch (light)

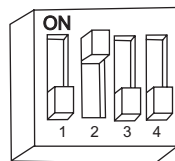

The fan is turned on in 10 seconds after the light in the room turns ON. After the light turns off, the fan keeps working for the time set with the RP2 regulator according to the table 2. Operating threshold is set with RP1 regulator. Yellow LED indicates illumination threshold exceeding. If the light stays turned on over 60 minutes, the fan turns off. The mode is activated by setting switch 2 into On position.

### 1.3 Outer signal control

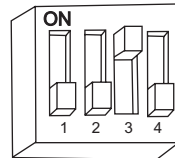

The fan is turned on in 3 seconds with the inner or outer switch. After being turned on it keeps working for the time set with RP2 regulator. The mode is activated by setting switch 3 into On position and can be combined with hygrostat and photo switch modes.

Combining with  
hygrostat mode

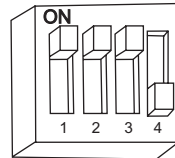

Combining with  
photo switch mode (dark)

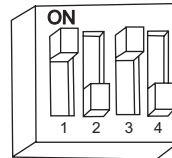

Combining with  
photo switch mode (light)

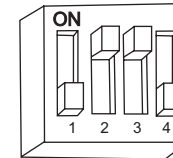

### 1.4 Moving sensor (option)

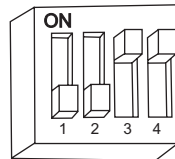

The fan is turned on after detecting movement of rather big object (for example human) in the sensor's operating range. Sensor's operating range is limited with 5 m distance and 130° viewing angle. After the movement ends the fan keeps working for the time set with RP2 regulator according to the table 2. The mode is activated by setting switches 3 and 4 into On position.

### 1.5 Cyclic

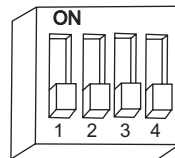

The fan is turned on periodically. It keeps working for the time set with RP2 switch and stays still for the time set with RP1 switch according to the table 2. The mode is activated by setting switches 1, 2, 3 and 4 into Off position.

2. Carry BU set-up with the help of potentiometers RP1 and RP2.  
Use screwdriver for this purpose.

By turning potentiometer's handle you configure parameters from the mode description.  
Setting handle on one of the six segments you can choose a value of needed parameter according to the table 2, 3.

**Table 2.** Time settings

Position	1	2	3	4	5	6
<b>Time</b>	5 sec.	5 sec.	10 sec.	15 sec.	20 sec.	30 sec.

**Table 3.** Moisture settings (option)

Position	1	2	3	4	5	6
<b>Moisture</b>	40...50 %	50...60 %	60...70 %	70...80 %	80...90 %	90...100 %

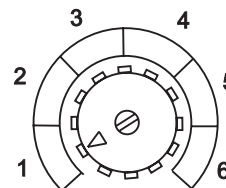

Keep BU in manufacturer's package in ventilated room under the temperature +5°C - +40°C and air humidity not over 60% (under the temperature +20°C).

The presence of acids, alkalis and other corrosive impurities in the air is not allowed.

**Storage  
precautions**

Manufacturer guaranties normal work of BU for 12 months from being bought in retail network if all the rules of transporting, keeping, mounting and using were followed.

The warranty doesn't cover devices with mechanical damage features.

With no sign of buying date, warranty period counts from the date of manufacture.

**Manufacturer's  
warranty**

If BU work fails during warranty period and it's manufacturer's fault, the customer has the right to change BU at the Manufacturer's according to art. 14 p. 9 of "The law about customers' right protection".

Warranty service and exchange:  
01030, Kiev, Kotsubynsky st., 1

