

## **GB** Forced draught gas burner

One-stage operation



CODE	MODEL	TYPE
3755119	RIELLO 40 GS3	551T1



**Translation of the original instructions**

<b>1</b>	<b>Declarations</b>	<b>3</b>
<b>2</b>	<b>Information and general warnings</b>	<b>4</b>
2.1	Information about the instruction manual	4
2.1.1	Introduction	4
2.1.2	General dangers	4
2.1.3	Other symbols	4
2.1.4	Delivery of the system and the instruction manual	5
2.2	Guarantee and responsibility	5
<b>3</b>	<b>Safety and prevention</b>	<b>6</b>
3.1	Introduction	6
3.2	Personnel training	6
<b>4</b>	<b>Technical description of the burner</b>	<b>7</b>
4.1	Burner designation	7
4.2	Models available	7
4.3	Burner categories - Countries of destination	7
4.4	Technical data	8
4.5	Maximum dimensions	8
4.6	Firing rate	9
4.6.1	Test boiler	9
4.6.2	Commercial boilers	9
4.7	Correlation between gas pressure and burner output	9
4.8	Burner description	10
4.9	Burner equipment	10
4.10	Electrical control box	11
4.11	Actuator	12
<b>5</b>	<b>Installation</b>	<b>13</b>
5.1	Notes on safety for the installation	13
5.2	Instructions to avoid burnout or bad combustion of the burner	13
5.3	Handling	13
5.4	Preliminary checks	14
5.4.1	Control of the supply	14
5.4.2	Control of burner characteristics	14
5.5	Operating position	14
5.6	Securing the burner to the boiler	15
5.7	Combustion head adjustment	15
5.8	Positioning the probe - electrode	16
5.8.1	Transformation to LPG (gas family 3)	16
5.9	Air damper adjustment	16
5.10	Gas feeding	17
5.10.1	Gas feeding line	17
5.10.2	Gas train	17
5.10.3	Gas train installation	18
5.11	Electrical wiring	19
5.11.1	Notes on safety for the electrical wiring	19
5.11.2	Control box	19
5.11.3	Electrical diagram	20
5.12	Operating programme	21
5.13	Table of times	22
5.13.1	Operating status indication	22
5.13.2	Fault diagnostics - lockouts	23
5.13.3	Checking the gas pressure switch	24
5.13.4	Checking the air pressure switch	24
5.13.5	Shut-down test	24
5.13.6	Intermittent operation	24
5.13.7	Recycle and limit of repetitions	24
5.13.8	Presence of an extraneous light or parasite flame	24
5.13.9	Duration of ignition transformer discharge	25
5.13.10	Reset by button and remotely of the burner	25
5.13.11	Protection reset	25
5.13.12	Reset button/Remote reset fault	25
5.13.13	External lockout signal (S3)	25

5.13.14	Hour counter function (B4).....	25
5.13.15	Monitoring the power supply voltage .....	25
5.13.16	Frequency supply error .....	25
5.13.17	Internal voltage fault.....	25
5.13.18	Checking the fan motor.....	26
5.13.19	Checking the faults of the gas valve and the motor .....	26
5.13.20	EEPROM check.....	26
5.13.21	Ionisation current .....	26
5.13.22	Post-purging.....	26
5.13.23	Continuous purging.....	26
5.13.24	Lockout log.....	27
5.13.25	Logging of burner operating parameters.....	27
5.13.26	Admissible lengths of the external connections to the burner.....	27
5.13.27	Long pre-purging.....	27
5.14	Programming menu .....	28
5.14.1	General notes .....	28
5.14.2	Block diagram for entering the menu .....	28
5.14.3	Shut-down test.....	29
5.14.4	Post-purging and continuous purging .....	29
5.14.5	Intermittent operation .....	29
5.14.6	Setting the long pre-purging.....	29
5.14.7	Displaying the lockout log .....	30
5.14.8	Resetting the programming menu parameters and the lockout log .....	30
5.15	Lockout types.....	31
<b>6</b>	<b>Start-up, calibration and operation of the burner .....</b>	<b>32</b>
6.1	Notes on safety for the first start-up.....	32
6.2	Adjustments prior to ignition.....	32
6.3	Combustion adjustment .....	32
6.4	Air pressure switch.....	32
<b>7</b>	<b>Maintenance .....</b>	<b>33</b>
7.1	Notes on safety for the maintenance .....	33
7.2	Maintenance programme .....	33
7.2.1	Maintenance frequency.....	33
7.2.2	Safety test - with gas ball valve closed .....	33
7.2.3	Checking and cleaning.....	33
7.2.4	Safety components .....	34
7.3	Opening the burner .....	34
<b>8</b>	<b>Faults - Possible causes - Solutions.....</b>	<b>35</b>
8.1	Start-up problems .....	35
8.2	Operating faults.....	36
<b>A</b>	<b>Appendix - Accessories .....</b>	<b>37</b>

**1** Declarations

**Declaration of conformity in accordance with ISO / IEC 17050-1**

Manufacturer:	RIELLO S.p.A.	
Address:	Via Pilade Riello, 7 37045 Legnago (VR)	
Product:	Forced draught gas burner	
Model:	RIELLO 40 GS3	
These products are in compliance with the following Technical Standards:		
EN 676		
EN 12100		
and according to the European Directives:		
GAR	2016/426/EU	Gas Appliances Regulation
MD	2006/42/EC	Machine Directive
LVD	2014/35/UE	Low Voltage Directive
EMC	2014/30/UE	Electromagnetic Compatibility
Such products are marked as follows:		
 <span style="margin-left: 100px;">EC-0476CT2714</span>		

The quality is guaranteed by a quality and management system certified in accordance with ISO 9001:2015.

**Declaration of Conformity A.R. 8/1/2004 & 17/7/2009 – Belgium**

Manufacturer:	RIELLO S.p.A. 37045 Legnago (VR) Italy Tel. ++39.0442630111 www.rielloburners.com	
Distributed by:	RIELLO NV Ninovesteenweg 198 9320 Erembodegem Tel. (053) 769 030 Fax. (053) 789 440 e-mail. info@riello.be URL. www.riello.be	
This document certifies that the series of devices specified below is in compliance with the model described in the EC Declaration of Conformity and has been manufactured and distributed in compliance with the requirements defined in the Legislative Decree of January 8th 2004 and July 17th 2009.		
Type of product:	Forced draught gas burner	
Model:	RIELLO 40 GS3	
Regulation applied:	EN 676 and A.R. of January 8th 2004 - July 17th 2009	
Controlling organisation:	Kiwa Gastec Italia S.p.A. Via Treviso, 32/34 31020 San Vendemiano (TV) Italy	
Values measured:	Max. CO:	70 mg/kWh
	Max. NOx:	118 mg/kWh

Legnago, 21.04.2018

Executive General Manager  
RIELLO S.p.A. - Burner Department  
Mr. U. Ferretti

Research & Development Director  
RIELLO S.p.A. - Burner Department  
Mr. F. Comencini

**2 Information and general warnings**

**2.1 Information about the instruction manual**

**2.1.1 Introduction**

The instruction manual supplied with the burner:

- is an integral and essential part of the product and must not be separated from it; it must therefore be kept carefully for any necessary consultation and must accompany the burner even if it is transferred to another owner or user, or to another system. If the manual is lost or damaged, another copy must be requested from the Technical Assistance Service of the area;
- is designed for use by qualified personnel;
- offers important indications and instructions relating to the installation safety, start-up, use and maintenance of the burner.

**Symbols used in the manual**

In some parts of the manual you will see triangular DANGER signs. Pay great attention to these, as they indicate a situation of potential danger.

**2.1.2 General dangers**

The **dangers** can be of **3 levels**, as indicated below.



Maximum danger level!  
This symbol indicates operations which, if not carried out correctly, cause serious injury, death or long-term health risks.



This symbol indicates operations which, if not carried out correctly, may cause serious injury, death or long-term health risks.



This symbol indicates operations which, if not carried out correctly, may cause damage to the machine and/or injury to people.

**2.1.3 Other symbols**



**DANGER: LIVE COMPONENTS**  
This symbol indicates operations which, if not carried out correctly, lead to electric shocks with lethal consequences.



**DANGER: FLAMMABLE MATERIAL**  
This symbol indicates the presence of flammable materials.



**DANGER: BURNING**  
This symbol indicates the risks of burns due to high temperatures.



**DANGER: CRUSHING OF LIMBS**  
This symbol indicates the presence of moving parts: danger of crushing of limbs.



**WARNING: MOVING PARTS**  
This symbol indicates that you must keep limbs away from moving mechanical parts; danger of crushing.



**DANGER: EXPLOSION**  
This symbol signals places where an explosive atmosphere may be present. An explosive atmosphere is defined as a mixture - under atmospheric conditions - of air and flammable substances in the form of gases, vapours, mist or dust in which, after ignition has occurred, combustion spreads to the entire unburned mixture.



**PERSONAL PROTECTION EQUIPMENT**  
These symbols indicate the equipment that must be worn and kept by the operator for protection against threats against safety and/or health while at work.



**OBLIGATION TO ASSEMBLE THE COVER AND ALL THE SAFETY AND PROTECTION DEVICES**  
This symbol signals the obligation to reassemble the cover and all the safety and protection devices of the burner after any maintenance, cleaning or checking operations.



**ENVIRONMENTAL PROTECTION**  
This symbol gives indications for the use of the machine with respect for the environment.



**IMPORTANT INFORMATION**  
This symbol indicates important information that you must bear in mind.

- This symbol indicates a list.

**Abbreviations used**

Ch.	Chapter
Fig.	Figure
Pag.	Page
Sec.	Section
Tab.	Table

**2.1.4 Delivery of the system and the instruction manual**

When the system is delivered, it is important that:

- the instruction manual is delivered to the user by the system manufacturer, with the recommendation to keep it in the room where the heat generator is to be installed.
- The instruction manual shows:
  - the serial number of the burner;

.....

- the address and telephone number of the nearest Assistance Centre;

.....  
 .....  
 .....

- The system supplier must carefully inform the user about:
  - the use of the system;
  - any further tests that may be required before activating the system;
  - maintenance, and the need to have the system checked at least once a year by a representative of the manufacturer or another specialised technician.
 To ensure a periodic check, the manufacturer recommends the drawing up of a Maintenance Contract.

**2.2 Guarantee and responsibility**

The manufacturer guarantees its new products from the date of installation, in accordance with the regulations in force and/or the sales contract. At the moment of the first start-up, check that the burner is integral and complete.



**WARNING**

Failure to observe the information given in this manual, operating negligence, incorrect installation and carrying out of non authorised modifications will result in the annulment by the manufacturer of the guarantee that it supplies with the burner.

In particular, the rights to the guarantee and the responsibility will no longer be valid, in the event of damage to things or injury to people, if such damage/injury was due to any of the following causes:

- incorrect installation, start-up, use and maintenance of the burner;
- improper, incorrect or unreasonable use of the burner;
- intervention of unqualified personnel;
- carrying out of unauthorised modifications on the equipment;
- use of the burner with safety devices that are faulty, incorrectly applied and/or not working;
- installation of untested supplementary components on the burner;
- powering of the burner with unsuitable fuels;
- faults in the fuel supply system;
- continuation of use of the burner when a fault has occurred;
- repairs and/or overhauls incorrectly carried out;
- modification of the combustion chamber with inserts that prevent the regular development of the structurally established flame;
- insufficient and inappropriate surveillance and care of those burner components most likely to be subject to wear and tear;
- use of non-original components, including spare parts, kits, accessories and optional;
- force majeure.

**The manufacturer furthermore declines any and every responsibility for the failure to observe the contents of this manual.**

## 3 Safety and prevention

### 3.1 Introduction

The burners have been designed and built in compliance with current regulations and directives, applying the known technical rules of safety and envisaging all the potential danger situations.

It is necessary, however, to bear in mind that the imprudent and clumsy use of the equipment may lead to situations of death risk for the user or third parties, as well as the damaging of the burner or other items. Inattention, thoughtlessness and excessive confidence often cause accidents; the same applies to tiredness and sleepiness.

It is a good idea to remember the following:

- The burner must only be used as expressly described. Any other use should be considered improper and therefore dangerous.

In particular:

it can be applied to boilers operating with water, steam, diathermic oil, and to other uses expressly foreseen by the manufacturer;

the type and pressure of the fuel, the voltage and frequency of the electrical power supply, the minimum and maximum deliveries for which the burner has been regulated, the pressurisation of the combustion chamber, the dimensions of the combustion chamber and the room temperature must all be within the values indicated in the instruction manual.

- Modification of the burner to alter its performance and destinations is not allowed.
- The burner must be used in exemplary technical safety conditions. Any disturbances that could compromise safety must be quickly eliminated.
- Opening or tampering with the burner components is not allowed, apart from the parts requiring maintenance.
- Only those parts envisaged by the manufacturer can be replaced.



The manufacturer guarantees safety and proper functioning only if all burner components are intact and positioned correctly.

### 3.2 Personnel training

The user is the person, body or company that has acquired the machine and intends to use it for the specific purpose. He is responsible for the machine and for the training of the people working around it.

The user:

- undertakes to entrust the machine exclusively to suitably trained and qualified personnel;
- undertakes to inform his personnel in a suitable way about the application and observance of the safety instructions. With that aim, he undertakes to ensure that everyone knows the use and safety instructions for his own duties.
- Personnel must observe all the danger and caution indications shown on the machine.
- Personnel must not carry out, on their own initiative, operations or interventions that are not within their province.
- Personnel must inform their superiors of every problem or dangerous situation that may arise.
- The assembly of parts of other makes, or any modifications, can alter the characteristics of the machine and hence compromise operating safety. The manufacturer therefore declines any and every responsibility for any damage that may be caused by the use of non-original parts.

In addition:



- must take all the measures necessary to prevent unauthorised people gaining access to the machine;
- the user must inform the manufacturer if faults or malfunctioning of the accident prevention systems are noticed, along with any presumed danger situation;
- personnel must always use the personal protective equipment envisaged by legislation and follow the indications given in this manual.



**4 Technical description of the burner**

**4.1 Burner designation**

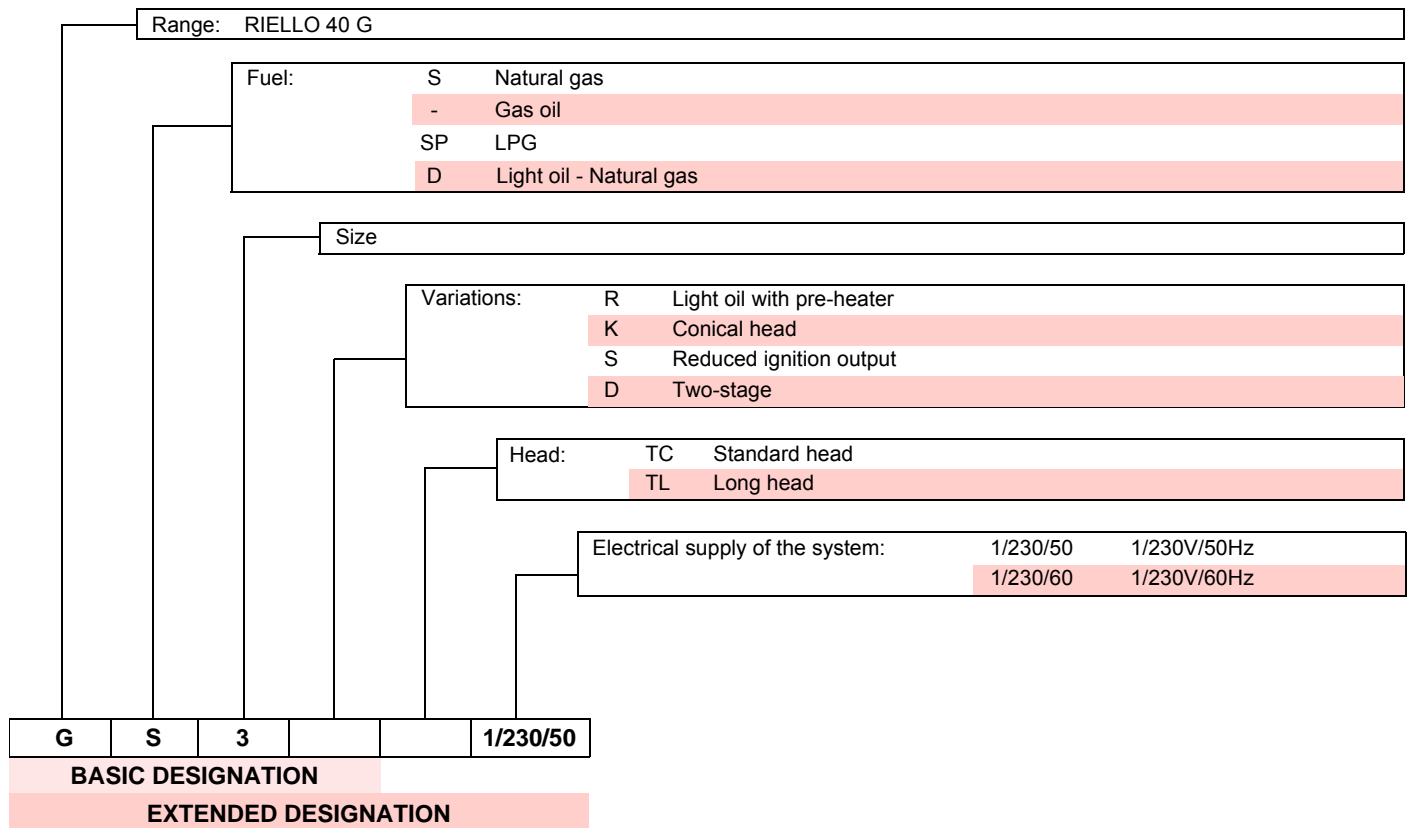

**4.2 Models available**

Designation	Voltage	Code
RIELLO 40 GS3	1/230/50	3755119

Tab. A

**4.3 Burner categories - Countries of destination**

Country of destination	Gas category
SE - FI - AT - GR - DK - ES - GB - IT - IE - PT - IS - CH - NO	I <sub>2H</sub>
DE	I <sub>2ELL</sub>
NL	I <sub>2L</sub> - I <sub>2E</sub> - I <sub>2</sub> (43,46 ÷ 45,3 MJ/m <sup>3</sup> (0°C))
FR	I <sub>2Er</sub>
BE	I <sub>2E(R)B</sub>
LU - PL	I <sub>2E</sub>

Tab. B

### 4.4 Technical data

Model			RIELLO 40 GS3
Type			551T1
Heat output (Hi) <sup>(1)</sup>	min - max	kW kcal/h	11 ÷ 35
			9.500 ÷ 30.000
Fuel	Family 2		NCV 8 ÷ 12 kWh/m <sup>3</sup> – 7,000 ÷ 10,340 kcal/m <sup>3</sup>
			Pressure: min. 10 mbar – max. 200 mbar
	Family 3		Ncv 24 ÷ 34 kWh/m <sup>3</sup> – 21.000 ÷ 29.300 kcal/m <sup>3</sup>
			Pressure: min. 8 mbar – max. 200 mbar
Operation			Intermittent (FS1)
Use			Boilers: water and diathermic oil
Ambient temperature		°C	0 - 50
Combustion air temperature		°C max	60
Electrical supply			1/230V/50Hz
Fan motor		rpm - rad/s	2800 - 294
		V - Hz	230 - 50
		W	90
		A	0.75
Ignition transformer			Primary 230V – Secondary 18 kV / 11 mA
Capacitor		µF	2
Absorbed electrical power		kW	0.15
Protection level			IP40
Weight		kg	11
Noise levels <sup>(2)</sup>	Sound pressure	dB(A)	53.8
	Sound power		65.0

Tab. C

<sup>(1)</sup> Reference conditions: Room temperature 20°C - Gas temperature 15°C - Barometric pressure 1013 mbar - Altitude 0 m a.s.l.

<sup>(2)</sup> Sound pressure measured in manufacturer's combustion laboratory, with burner operating on test boiler and at maximum rated output. The sound power is measured with the "Free Field" method, as per EN 15036, and according to an "Accuracy: Category 3" measuring accuracy, as set out in EN ISO 3746.

### 4.5 Maximum dimensions

The maximum dimensions of the flange and burner are given in Fig. 1.

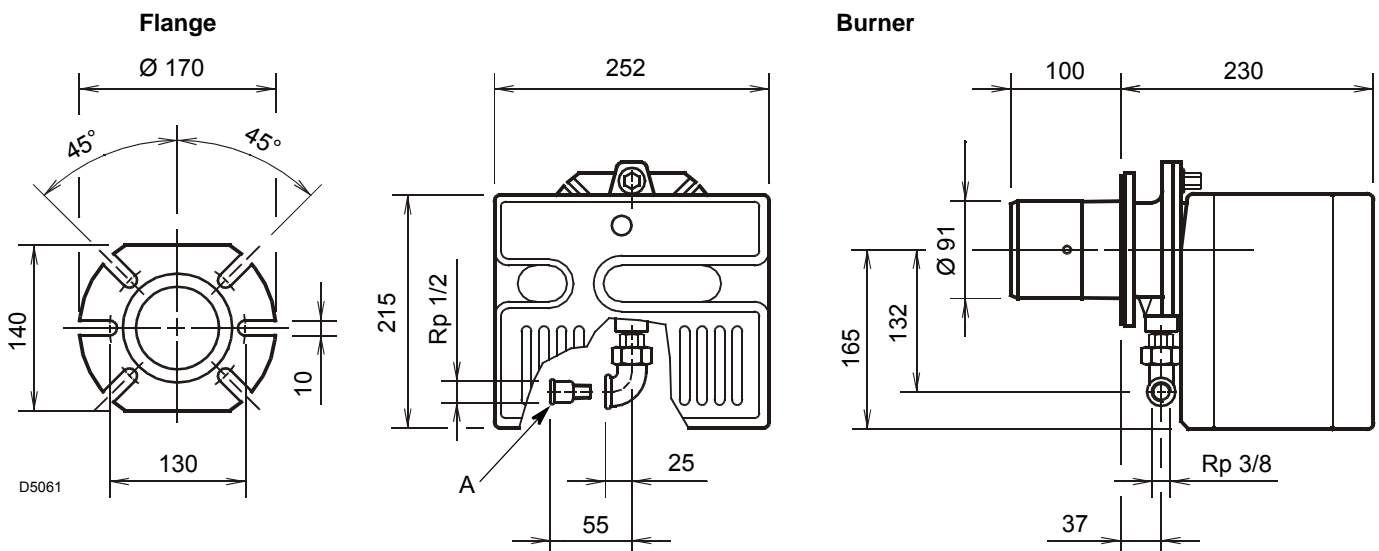

Fig. 1

Key (Fig. 1)

A Reduction pipe coupling Rp 1/2 - R 3/8

**4.6 Firing rate**

The burner output is chosen from within the diagram area (Fig. 2).



The firing rate value (Fig. 2) has been obtained considering an ambient temperature of 20°C, an atmospheric pressure of 1013 mbar (approx. 0 m above sea level), and with the combustion head adjusted as shown on pag. 15.

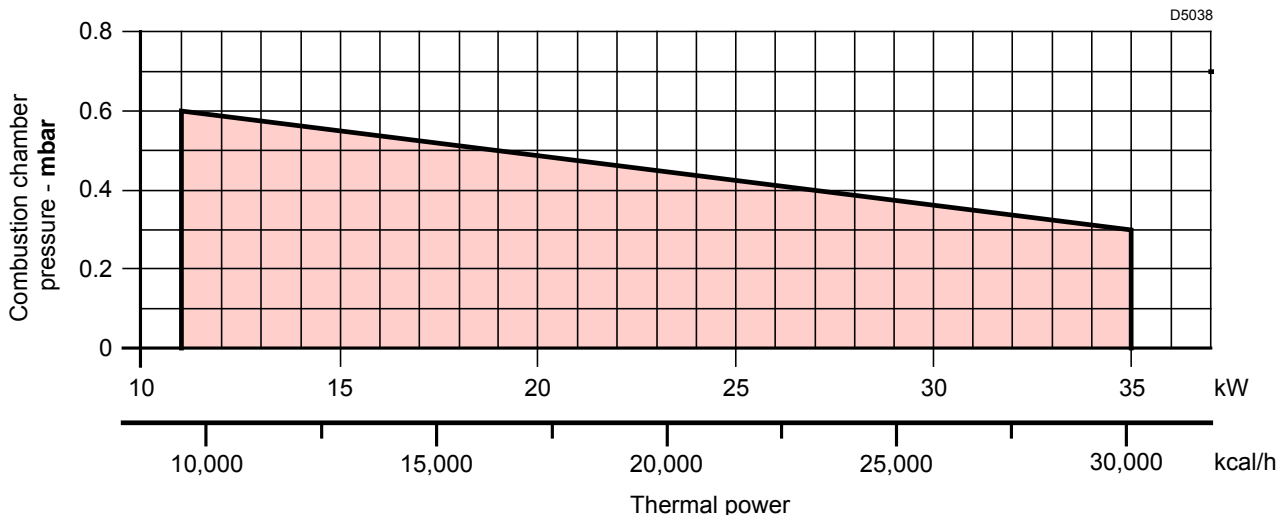

**Fig. 2**

**4.6.1 Test boiler**

The firing rate has been defined according to EN 676 standard.

For applications where the boiler does not conform to EN 303, or where the combustion chamber is much smaller than the dimensions given in EN 676, please consult the manufacturers.

**4.6.2 Commercial boilers**

The burner-boiler matching is assured if the boiler conforms to EN 303 and the combustion chamber dimensions are similar to those shown in the diagram EN 676.

**4.7 Correlation between gas pressure and burner output**

To obtain the maximum output (Fig. 3), it is necessary to have 4.5 mbar measured on the pipe coupling, with the combustion cham-

ber at 0 mbar and gas G20 - NCV = 10 kWh/Nm<sup>3</sup> (8,570 kcal/Nm<sup>3</sup>).

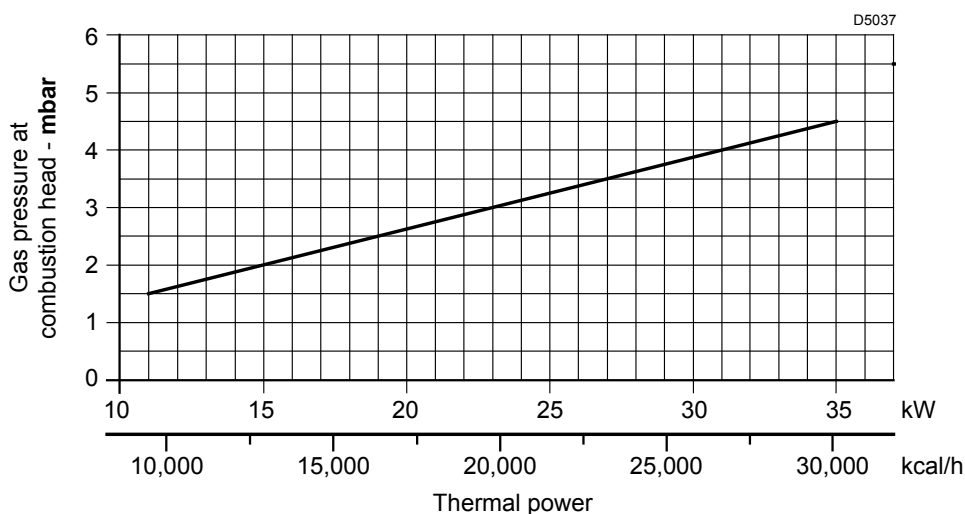

**Fig. 3**

**4.8 Burner description**

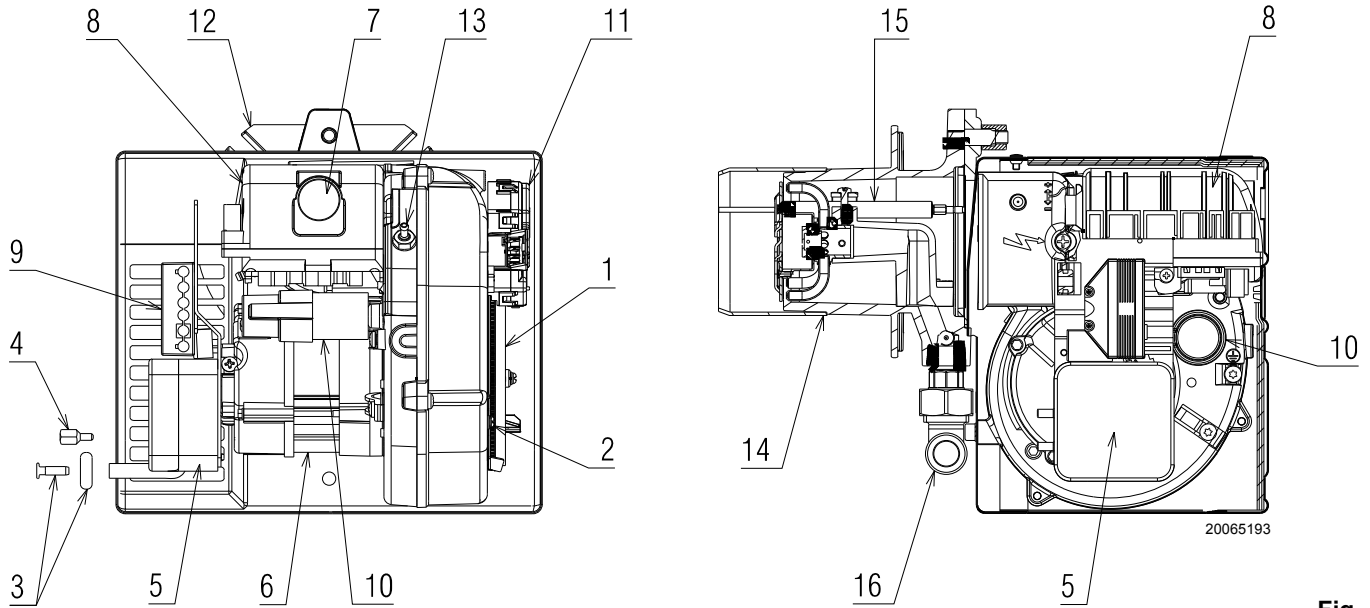

**Fig. 4**

- |    |                                   |    |                         |
|----|-----------------------------------|----|-------------------------|
| 1  | Air dampers                       | 11 | Actuator                |
| 2  | Damper fixing screws              | 12 | Flange                  |
| 3  | Pressure test point (-)           | 13 | Pressure test point (+) |
| 4  | Cover fixing screw                | 14 | Combustion head         |
| 5  | Air pressure switch               | 15 | Electrode-probe         |
| 6  | Motor                             | 16 | Gas train elbow         |
| 7  | Lock-out signal with reset button |    |                         |
| 8  | Control box                       |    |                         |
| 9  | 6 pole socket for gas train       |    |                         |
| 10 | Capacitor                         |    |                         |



The supplied grommet and the cover fixing screw should be assembled on the same side as the gas train.

**4.9 Burner equipment**

Screws with nuts	No. 4	For LPG burner:	
Insulating gasket	No. 1	Diffuser	No. 1
Cover fixing screw	No. 1	Reducer	No. 1
Cable grommet	No. 1	Self-adhesive label	No. 1
Reducing pipe coupling Rp 1/2 - R 3/8	No. 1	Instructions	No. 1
7-pin plug	No. 1		
Instructions	No. 6		
Spare parts list	No. 1		

**4.10 Electrical control box**

The control box is a control and supervision system for forced draught burners, for intermittent operation (at least one controlled shutdown every 24 hours).

**Important notes**



To avoid accidents, material or environmental damage, observe the following instructions!

The control box is a safety device! Avoid opening or modifying it, or forcing its operation. The Manufacturer cannot assume any responsibility for damage resulting from unauthorised work!

- All interventions (assembly and installation operations, assistance, etc.) must be carried out by qualified personnel.
- Before modifying the wiring in the control box connection area, fully disconnect the system from the power supply (omnipolar separation).
- Protection against electrocution from the control box and all connected electric components is obtained with the correct assembly.
- Before any intervention (assembly and installation operations, assistance, etc.), ensure the wiring is in order and that the parameters are correctly set, then make the safety checks.
- Falls and collisions can negatively affect the safety functions.  
In this case, the control box must not be operated, even if it displays no evident damage.

For safety and reliability, comply with the following instructions:

- avoid conditions that can favour the development of condensate and humidity. Otherwise, before switching on again, make sure the control box is perfectly dry.
- Static charges must be avoided since they can damage the control box's electronic components when touched.

**Installation notes**

- Check the electrical wiring inside the boiler complies with the national and local safety regulations.
- Install switches, fuses, earth connection etc. in compliance with local regulations.
- Do not confuse the powered conductors with the neutral ones.
- Ensure that spliced wires cannot get into contact with neighbouring terminals. Use adequate ferrules.
- Arrange the H.V. ignition cables separately, as far as possible from the control box and the other cables.
- When wiring the unit, make sure the 230V AC mains voltage cables are run strictly separate from extra low-voltage cables, to avoid the risk of electrocution.

To remove the control box from the burner it is necessary to (Fig. 5):

- disconnect all the connectors connected to it, all the plugs, the high voltage cables and the earth wire (TB);
- unscrew the screw (A) and pull the control box in the direction of the arrow.

To install the control box it is necessary to:

- tighten the screw (A) with a tightening torque of 1 - 1.2 Nm;
- reconnect all previously disconnected connectors, making sure to connect the 7 pin plug as the final step.

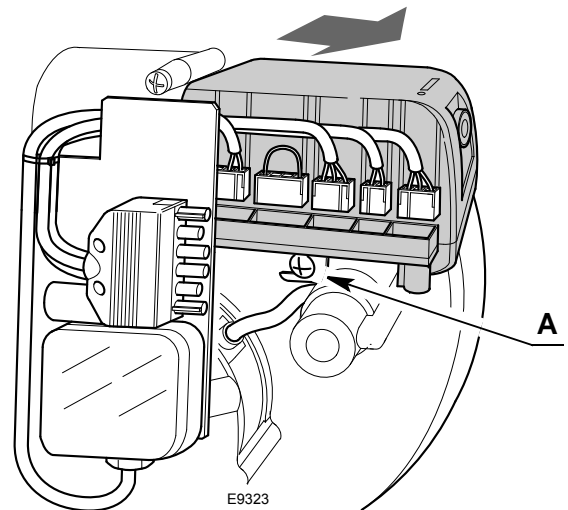

**Fig. 5**

**NOTE:**

**The burners have been approved for intermittent operation. This means that they must stop once every twenty four hours to permit the electrical control box to check its efficiency at start-up. The boiler limit thermostat (TL) normally ensures the stopping of the burner. If this is not the case, it is necessary to apply a timer switch in series to the limit thermostat (TL) that turns off the burner at least once every 24 hours.**

**Electrical wiring of ionisation probe**

It is important for signal transmission to be almost totally free of any disturbances or loss:

- Always separate the probe cables from the other cables:
  - the line capacity reduces the magnitude of the flame signal;
  - use a separate cable.
- The cable length must not exceed 1 m.
- Respect the polarity
- Insulation resistance
  - must be at least 50 MΩ between the ionisation probe and the earth;
  - a dirty detector reduces the insulation resistance, fostering leakage currents.
- The ionisation probe is not protected against the risk of electrocution. When connected to the electricity supply, the ionisation probe must be protected against any accidental contact.
- Position the ionisation probe so that the ignition spark cannot form an arc on the probe (risk of electric overcharge).

**Technical data**

Mains voltage	AC 210...230 V -15 % / +10 %
Mains frequency	50/60 Hz ±6 %
Built-in fuse	T5A 250V
Energy consumption	40 VA
Protection level	IP00

**Tab. D**

4.11 Actuator

Warnings



To avoid accidents, material or environmental damage, observe the following instructions!

Avoid opening, modifying or forcing the actuators.

- All interventions (assembly and installation operations, assistance, etc.) must be carried out by qualified personnel.
- Before modifying the wiring in the connection area or the actuator, fully disconnect the burner control device from the power supply (omnipolar separation).
- To avoid the risk of electrocution, protect the connection terminals in a suitable manner and correctly fix the cover.
- Check the wiring is in order.
- Falls and collisions can negatively affect the safety functions. In this case, the servomotor must not be operated, even if it displays no evident damage.

Assembly notes

- The actuator is mounted on the burner air setting with an inclination of 7°.
- Check the relevant national safety standards are respected.

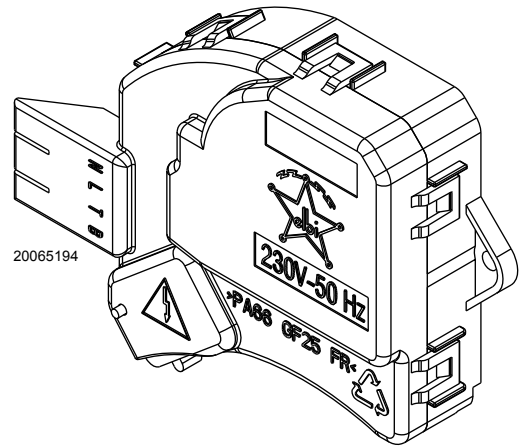

Fig. 6

Technical characteristics

Voltage and frequency	230V(+10%;-15%) - 50Hz
Operating temperature	70 °C
Working times:	
- opening of the suction line	3.35" sec
- closure of the suction line	4.35" sec
Protection level	IP20 - according to DIN 40 050 mounted on the burner

**5 Installation**

**5.1 Notes on safety for the installation**

After carefully cleaning all around the area where the burner will be installed, and arranging the correct lighting of the environment, proceed with the installation operations.



All the installation, maintenance and disassembly operations must be carried out with the electricity supply disconnected.



The installation of the burner must be carried out by qualified personnel, as indicated in this manual and in compliance with the standards and regulations of the laws in force.



Combustion air inside the boiler must be free from hazardous mixes (e.g.: chloride, fluoride, halogen); if present, it is highly recommended to carry out cleaning and maintenance more frequently.

**5.2 Instructions to avoid burnout or bad combustion of the burner**

- 1 The burner can not be installed outside as it is suitable for operation in closed rooms only.
- 2 The premises the burner operates in must have openings for the air need for the combustion.  
To be sure about this, you have to control CO<sub>2</sub> and CO in the exhaust gases with all the windows and doors closed.
- 3 If there are air extractors in the premises the burner works, make sure that there are openings for air to be taken in that

- 4 are big enough to ensure the required air change; In any case, check that when the burner stops the extractors do not draw hot fumes from pipes through the burner.
- 4 When the burner is stopped, the smoke pipe must be kept open and a natural draft created in the combustion chamber. If the smoke pipe is closed, the burner must be drawn back till the extraction of blast tube from the furnace. Before operating in this way take the voltage off.

**5.3 Handling**

The transport weight is given in chapter “Technical data” on page 8.

Observe the permissible ambient temperatures for storage and transport: -20 ..... + 70 °C, with max. relative humidity. 80%.



After positioning the burner near the installation point, correctly dispose of all residual packaging, separating the various types of material.



Before proceeding with the installation operations, carefully clean all around the area where the burner will be installed.



The operator must use the required equipment during installation.

### 5.4 Preliminary checks

#### 5.4.1 Control of the supply



After removing all the packaging, check the integrity of the contents.

In the event of doubt, do not use the burner; contact the supplier.



The packaging elements (cardboard box, clips, plastic bags, etc.) must not be abandoned as they are potential sources of danger and pollution; they should be collected and disposed of in the appropriate places.



A burner label that has been tampered with, removed or is missing, along with anything else that prevents the definite identification of the burner makes any installation or maintenance work difficult.



The figure of the label (Fig. 7) is indicative. Some of the data may be arranged in a different position.

#### 5.4.2 Control of burner characteristics

Check the identification label of the burner (Fig. 7), showing:

- A the burner model;
- B the burner type;
- C the cryptographic year of manufacture;
- D the serial number;
- E the data for electrical supply and the protection level;
- F the electrical power consumption;
- G the data of the burner's minimum and maximum output possibilities (see Firing rate)

**Warning.** The burner output must be within the boiler's firing rate.

R.B.L.		A				TYP TYPE ΤΥΠΟΣ		B	B	C
		D				E		F		
I12ELL 3B/P DE	I12H3P GB, IE,ES	I12E 3B/P LU	I12L 3B/P NL	GAS GAZ ΑΕΠΙΟΥ		<input checked="" type="checkbox"/> FAM.OIK.2 <input type="checkbox"/> FAM.OIK.3		G		
I12H3B/P DK,AT, GR,SE	Icc	A	Imax Peso Kg		RIELLO S.p.A. I-37048 Legnago (VR)		CE			

20065195

Fig. 7

### 5.5 Operating position



- The burner is designed to operate only in positions 1, 2, 3 and 4 (Fig. 8).
- Installation 1 is preferable, as it is the only one that allows the maintenance operations as described in this manual.
- Installations 2, 3 and 4 permit operation but make maintenance and inspection of the combustion head more difficult.



- Any other position could compromise the correct operation of the appliance.
- Installation 5 is prohibited for safety reasons.

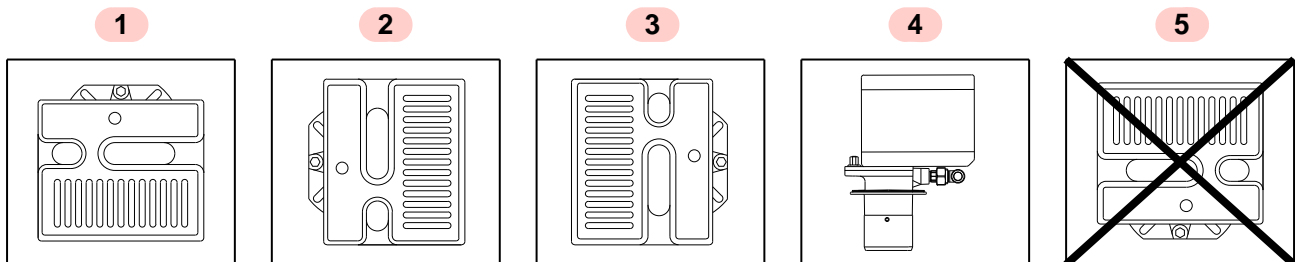

20065196

Fig. 8



**5.6 Securing the burner to the boiler**



Provide an adequate lifting system of the burner.

- Separate the combustion head assembly from the burner body by removing nut 1) and removing the group A)(Fig. 9).
- Fix the group B)(Fig. 9) to the boiler plate 2), inserting the supplied insulating gasket 3).



**The seal between burner and boiler must be airtight.**

WARNING

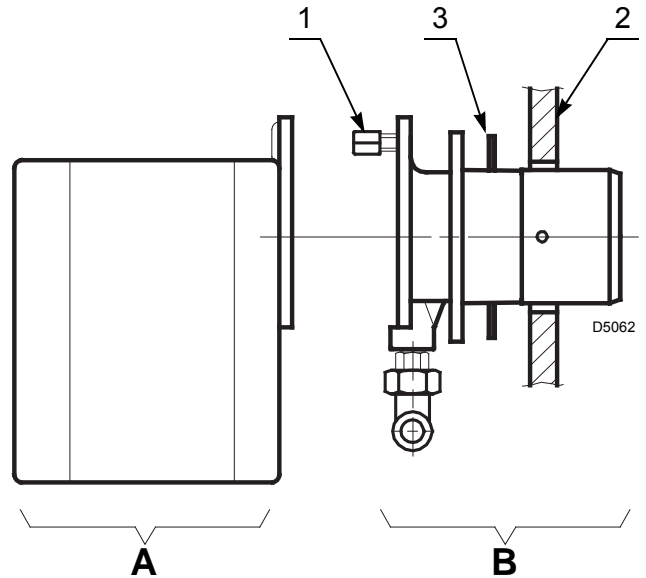

Fig. 9

**5.7 Combustion head adjustment**

To adjust, proceed as follows:

- loosen the two screws A)(Fig. 10), move the elbow B) so that the rear plate of the coupling C) coincides with the desired notch;
- screw in the two screws A).

To disassemble the diffuser disc holding head, proceed as follows:

- loosen the two screws A)(Fig. 10) without removing them;
- pull back the head, rotating it by about 180°;
- extract the head, tilting it downwards.

**Example:**

The burner is installed in a 21 kW boiler. Considering an efficiency of 90%, the burner must supply around 23kW.

The diagram (Fig. 11) shows that for this output the adjustment must be made on notch 1.

The diagram is to be used only for initial settings,. To ensure good air pressure switch operation it may be necessary to reduce this combustion head opening (notch toward pos. 0).

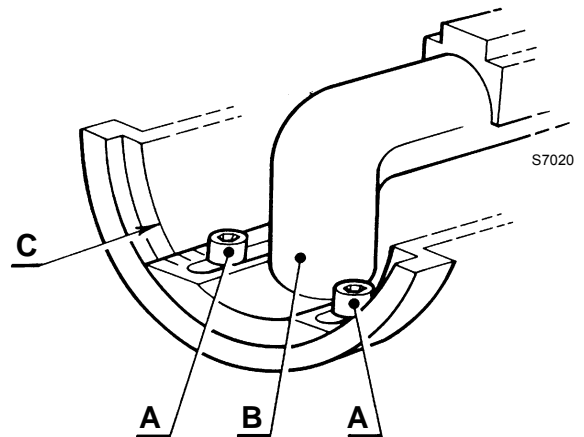

Fig. 10

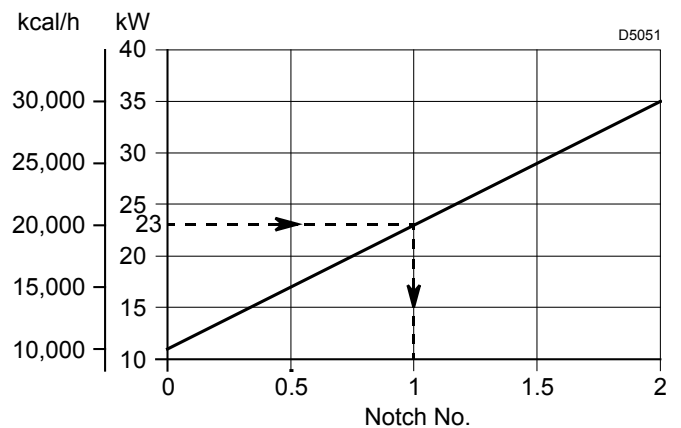

Fig. 11

**5.8 Positioning the probe - electrode**



Do not turn the ignition electrode but leave it as shown in Fig. 12.  
if the ignition electrode is put near the ionisation probe, the control box amplifier might be damaged.



Place the ceramic part of the electrode A) against the diffuser disc B)(Fig. 12).

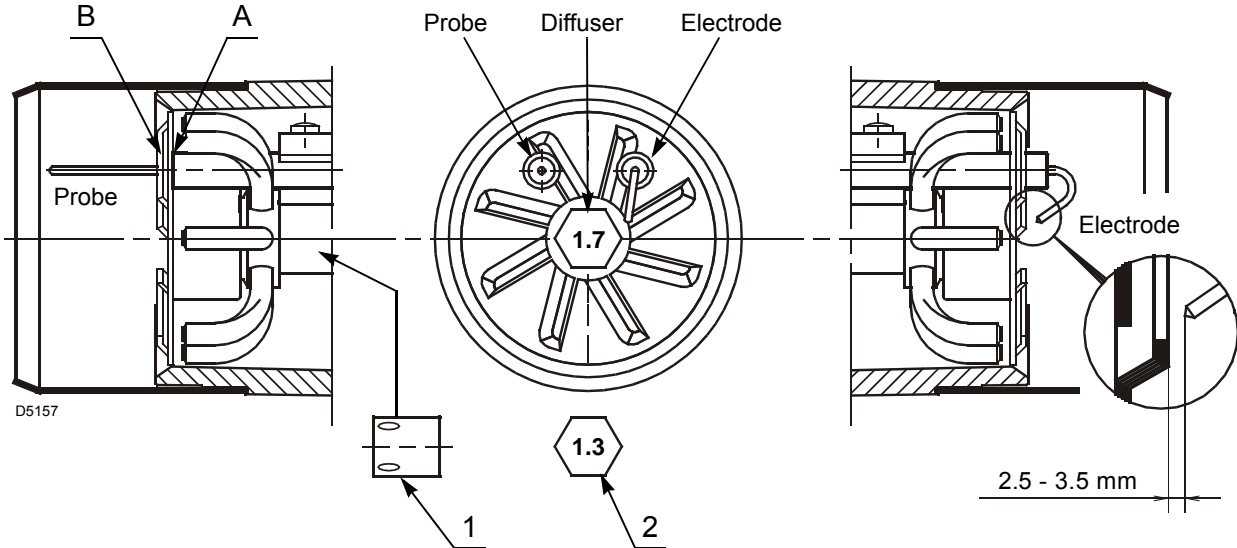

**Fig. 12**

**5.8.1 Transformation to LPG (gas family 3)**

To transform the burner, it is necessary to:

- insert the reducing element 1)(Fig. 12);

- insert the new diffuser 2) with the stamp 1.3;
- apply the self-adhesive label coming as standard.

**5.9 Air damper adjustment**

Actuator 1)(Fig. 13) controls the air damper 6); the burner does not start until the damper 6) is completely open.

To adjust the fixed damper 4) it is necessary to:

- loosen the screws 3) and 5) and rotate the damper as far as the required point 2).
- Once optimum adjustment has been reached, fix the screws 3) and 5).

The adjustment of the damper varies in each single application, so it is necessary to use a calibration tool to obtain an efficient combustion result.



It is advisable to carry out an analysis of the combustion values with the cover assembled.

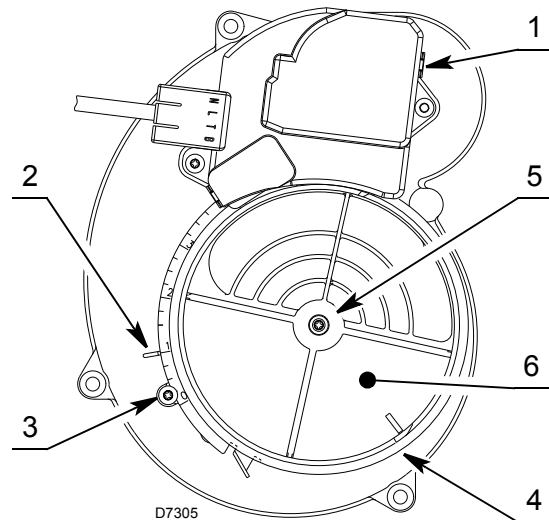

**Fig. 13**

**5.10 Gas feeding**



Explosion danger due to fuel leaks in the presence of a flammable source.

Precautions: avoid knocking, attrition, sparks and heat.

Make sure the fuel interception tap is closed before performing any operation on the burner.



**WARNING**

The fuel supply line must be installed by qualified personnel, in compliance with current standards and laws.

**5.10.1 Gas feeding line**

**MBC 65/1**

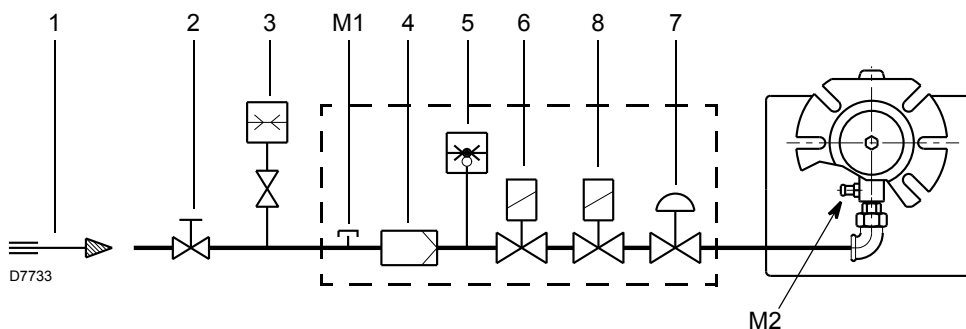

**Fig. 14**

Key (Fig. 14)

- 1 Gas input pipe
- 2 Manual gate (the responsibility of the installer)
- 3 Gas pressure gauge (the responsibility of the installer)
- 4 Filter
- 5 Gas pressure switch
- 6 Safety valve
- 7 Pressure stabiliser
- 8 Adjustment valve

- M1 Gas-supply pressure test point on the gas pressure switch
- M2 Pressure coupling test point

**5.10.2 Gas train**

Approved according to standard EN 676 and provided separately from the burner. Supplied separately for its adjustment, see the enclosed instructions.

The train-burner combination is indicated in Tab. E.

Code	Model	Connections		Use
		Gas train	Burner	
3970569	MBC 65/1 - RSD 20	Rp 1/2	Rp 1/2	Natural gas and LPG

**Tab. E**

**5.10.3 Gas train installation**



Disconnect the electrical power using the main switch.



Check that there are no gas leaks.



Pay attention when handling the train: danger of crushing of limbs.



Make sure that the gas train is properly installed by checking for any fuel leaks.

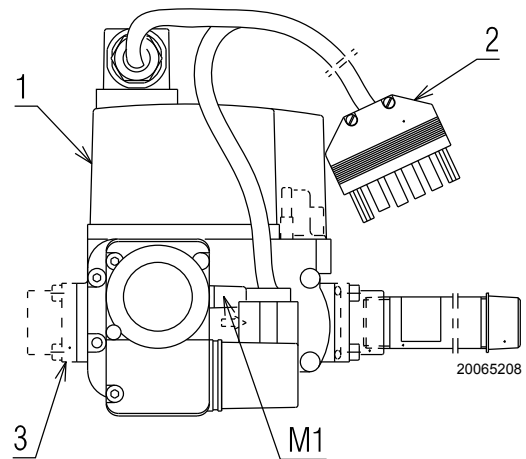

**Fig. 15**

The gas train 1)(Fig. 15) leaves the factory ready for installation to the burner's left.

If it is to be installed on the right, fit the valve turned by 90° with respect to the gas-out flange and with the gas pressure switch pointed upwards.

Connection between the gas supply line and the train must be made using the gas-in flange 3) supplied, and fastening screws.



It is best to tighten screws in a criss-cross pattern. Do not, under any circumstances, install the valve with the coil facing down.

Connect the 6 pin plug 2)(Fig. 15) of the gas train to the 6-pole socket 9)(Fig. 4 on pag. 10) of the burner.



Once installation is complete, you must check for fuel leaks and make sure the gas train is working properly.

**5.11 Electrical wiring**

**5.11.1 Notes on safety for the electrical wiring**



- The electrical wiring must be carried out with the electrical supply disconnected.
- Electrical wiring must be made in accordance with the regulations currently in force in the country of destination and by qualified personnel. Refer to the wiring diagrams.
- The manufacturer declines all responsibility for modifications or connections different from those shown in the wiring diagrams.
- Check that the electrical supply of the burner corresponds to that shown on the identification label and in this manual.
- The burner has been type-approved for intermittent use.  
In the event of continuous operation, a cycle arrest must be ensured within 24 hours with the use of a time switch positioned in series with the thermostatic line. Refer to the wiring diagrams.
- The electrical safety of the device is obtained only when it is correctly connected to an efficient earthing system, made according to current standards. It is necessary to check this fundamental safety requirement. In the event of doubt, have the electrical system checked by qualified personnel. Do not use the gas tubes as an earthing system for electrical devices.
- The electrical system must be suitable for the maximum power absorption of the device, as indicated on the label and in the manual, checking in particular that the section of the cables is suitable for that level of power absorption.
- For the main power supply of the device from the electricity mains:
  - do not use adapters, multiple sockets or extensions;
  - use a multiple pole switch with at least a 3 mm gap between the contacts (overvoltage category III), as envisaged by the present safety standards.
- Do not touch the device with wet or damp body parts and/or in bare feet.
- Do not pull the electric cables.

Before carrying out any maintenance, cleaning or checking operations:



Disconnect the electrical supply from the burner by means of the main system switch.



Turn off the fuel interception tap.



Avoid condensate, ice and water leaks from forming.

If the cover is still present, remove it and proceed with the electrical wiring according to the wiring diagrams.

**5.11.2 Control box**



Disconnect the electrical supply from the burner by means of the main system switch.

To remove the control box from the burner it is necessary to:

- disconnect all the connectors connected to it, the 6-pin plug, the high voltage cables, and the earth wire (TB);
- loosen the screw 1)(Fig. 16) and pull the control box in the direction of the arrow.

For the installation:

- tighten screw 1)(Fig. 16) with a tightening torque of  $1 \div 1.2$  Nm;
- reconnect all previously disconnected connectors, making sure to connect the 7 pin power plug as the final step.



After carrying out maintenance, cleaning or checking operations, reassemble the cover and all the safety and protection devices of the burner.

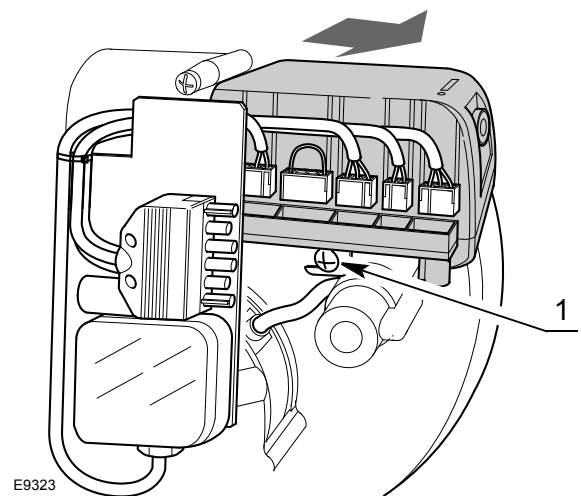

**Fig. 16**

**5.11.3 Electrical diagram**

Key (Fig. 17)

- AD Air damper opening motor
- C Motor capacitor
- CN1 Ionisation probe connector
- E Ignition electrode
- F Filter
- h1 Hour counter (230V - 0.1A max.)
- MV Fan motor
- PA Air pressure switch
- PG Min. gas pressure switch
- RS Remote reset connection
- SB Lockout light (230V - 0.5A max.)
- SM One-stage damper conn.
- SO Ionisation probe
- TB Burner earth
- TL Limit thermostat
- TS Safety thermostat
- T6A Fuse
- V1 Adjustment valve
- VS Safety valve
- XP6 6 pin plug/socket
- XP7 7 pin/plug socket



- Do not invert the neutral with the phase in the electrical supply line.
- Check that the electrical supply of the burner corresponds to that shown on the identification label and in this manual.
- The section of the conductors must be at least 1mm<sup>2</sup>. (Unless requested otherwise by local standards and legislation).



Check the burner stops by opening the thermostats and check it locks out by opening the connector (CN1) (Fig. 17) inserted in the probe's red wire, located on the outside of the control box.



If the cover is still on, remove it and proceed with the electric wiring following the wiring diagrams.  
Use flexible cables in compliance with EN 60 335-1 standards.

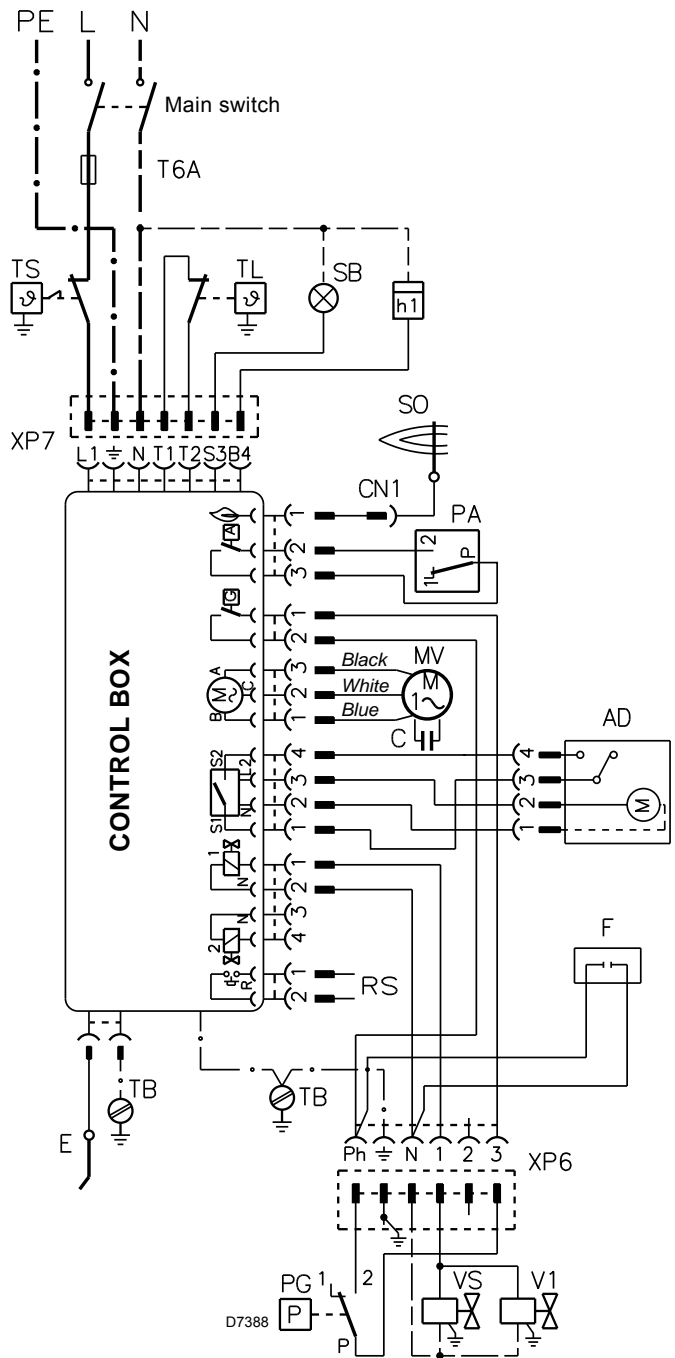

**Fig. 17**

5.12 Operating programme

Normal operation

20147598

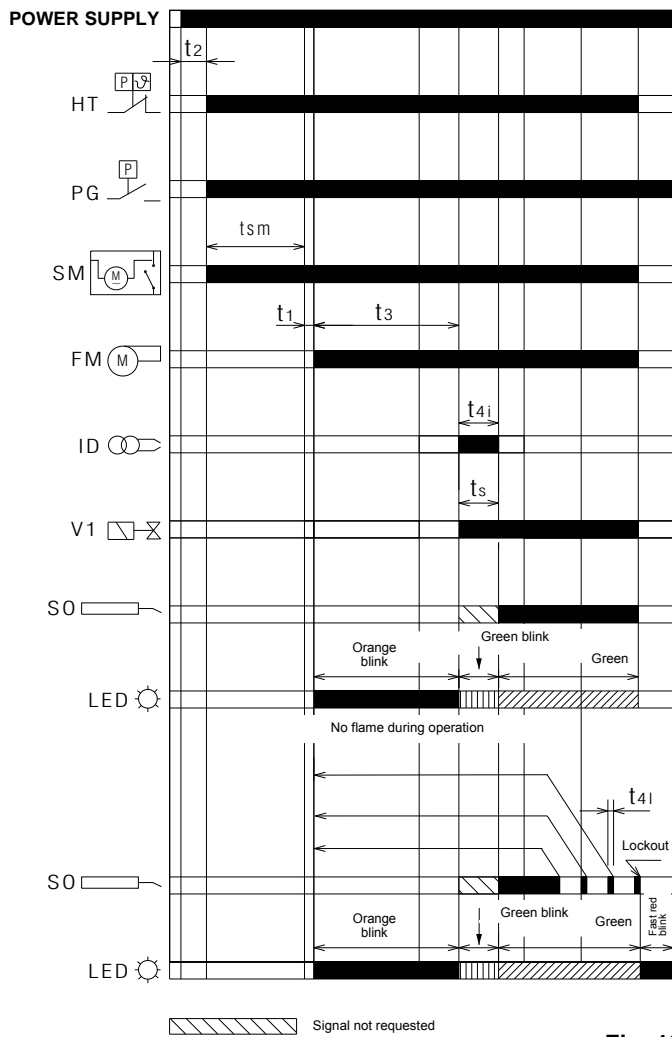

Fig. 18

Lockout due to extraneous light during pre-purging

20147599

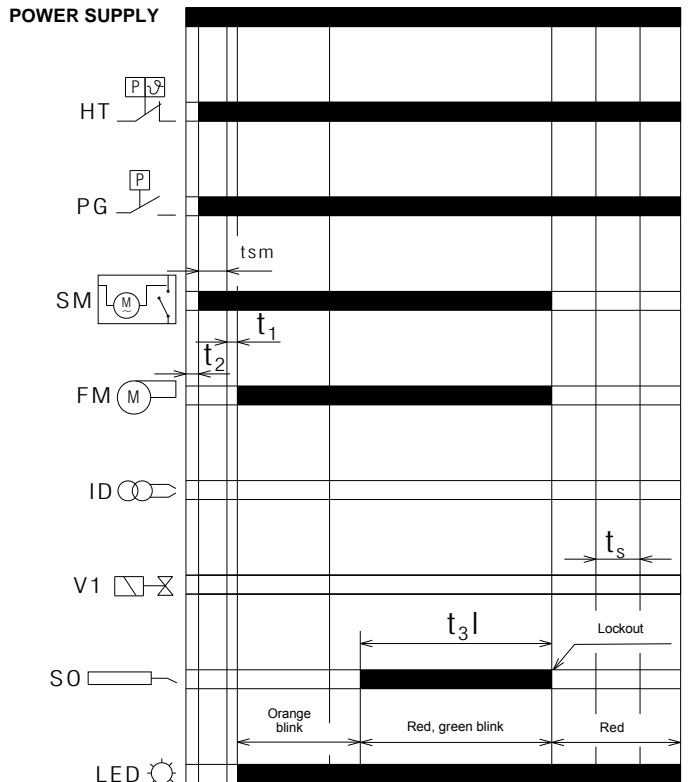

Fig. 20

Key to layout

- FM – Fan motor
- HT – Heat request
- ID – Ignition device
- LED – LED colour inside the button
- SM – Electric servomotor damper opener
- PG – Low gas pressure switch
- SO – Ionisation probe
- t1 – Standby time
- t2 – Initialisation time for checking
- t3 – Pre-purging time
- t3l – Checks for presence of extraneous light during pre-purging phase
- t4i – Total ignition time
- t4l – Reaction time to achieve safety lockout due to lack of failure
- ts – Safety time
- t<sub>sm</sub> – Standby time for servomotor opening of the electric damper opener
- V1 – Gas valve

Lockout due to ignition failure

20147600

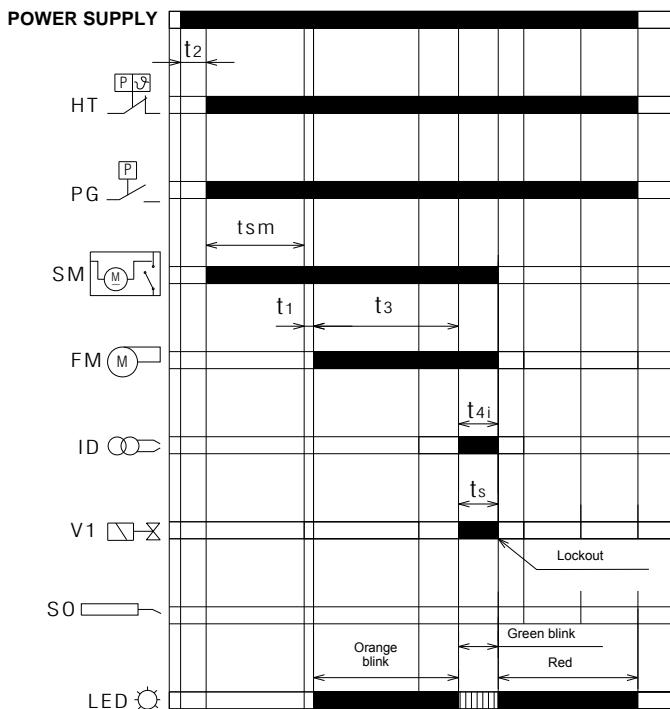

Fig. 19

**5.13 Table of times**

Symbol	Description	Value (sec.)
t0	Standby: the burner is waiting for the heat request, the closure of the gas pressure switch, the opening of the air pressure switch	-
t1	Standby time for an input signal: reaction time, control box remains in waiting mode for t1	2
t1l	Flame or flame simulation detected before demand for heat: the control box remains idle.	25
t2	Initialisation standby time: checking time following the main power start-up	< 4.5
t2l	Checks extraneous light or parasite flame during t2: waiting mode for t2l, then lockout: the motor does not start	25
t2a	Check whether the air pressure switch has already been moved to the work position before the required heat: the control box remains in standby status, a lockout follows if the air pressure switch remains switched for the <b>T2a</b> time.	max 120
t3	Pre-purging time: the fan motor is running, then the gas valve is activated	40
t3l	Checks extraneous light or parasite flame during pre-purging: control box goes into lockout at the end of t3l	1
t3a	Time for checking the switching of the air pressure switch in the operating position during the pre-purging time: if the pressure switch does not change over within <b>t3a</b> there is a lockout.	max 15
t3r	A recycle attempt is made if there is an air pressure drop during the pre-purging stage: there is then a lockout in the event of a second loss of air pressure between the 16th second and the 29th; in a loss of pressure between the 30th second and the 40th, the control box goes immediately into lockout mode.	-
ts	Safety time	5
t4i	Total spark ignition time	5
t4a	Air pressure drop checking time during the <b>ts</b> time and the normal operation: the control box locks out immediately.	< 1
t4l	Reaction time to achieve safety deactivation due to flame loss	< 1
-	Minimum time to reset the control box using reset button	0.4
-	Minimum time to reset the control box using remote reset	0.8
tr	Re-cycles: max. 3 repeats of the complete start-up sequence in the case of flame loss during operation; the final action at the last attempt following flame failure is a lockout	3 re-cycles
tsm	Standby time for servomotor opening of the electric damper opener	~ 4

**Tab. F**

**5.13.1 Operating status indication**

Status	Reset button colour	Seconds		Colour code
Waiting for a heat request, waiting for the closure of the gas pressure switch, waiting for the opening of the air pressure switch	-	-	-	-
Awaiting heat request with continuous purging	ORANGE Blink	0.5	2.5	●○●○●○●○●○
Pre-purging, or awaiting air pressure switch closure, or long pre-purging	ORANGE Blink	0.5	0.5	●○●○●○●○●○
Safety time without flame	GREEN Blink	0.5	0.5	■□■□■□■□■□
Safety time with flame	GREEN	-	-	■■■■■■■■■■■■■■■■
Normal operating position	GREEN	-	-	■■■■■■■■■■■■■■■■

**Tab. G**

**Key to layout**

ON	OFF	Colour code
▲	△	RED
●	○	ORANGE
■	□	GREEN

**Tab. H**



5.13.2 Fault diagnostics - lockouts

Fault description	Reset button colour	Seconds		Colour code
Extraneous light (false flame signal)	GREEN, RED blinking alternately	0.5	0.5	■▲■▲■▲■▲■▲■▲
Gas pressure switch not closing fault or contact open of the electric damper opener of the solenoid valve SM, 2 minutes after the heat request	ORANGE blinking inverted	2.5	0.5	●○●○●○●○●○●○
Electrical power voltage fault	ORANGE slow blinking	2.5	2.5	●○●○●○●○●○●○
Electrical power frequency fault	ORANGE	-	-	●●●●●●●●●●●●
Flame control voltage fault	ORANGE, GREEN fast blinking alternately	0.2	0.2	●■●■●■●■●■●■
Reset button / Remote reset fault	GREEN, RED fast blinking alternately	0.2	0.2	■▲■▲■▲■▲■▲■▲
Lockout for no flame after Ts	RED	-	-	▲▲▲▲▲▲▲▲▲▲▲▲
Lockout for extraneous light signal or for parasite flame	RED blink	0.5	0.5	▲△▲△▲△▲△▲△▲△
Lockout for maximum number of cycle repetitions (flame loss during operation)	RED Fast blinking	0.2	0.2	▲△▲△▲△▲△▲△▲△
Lockout due to loss of air pressure or after repetition of the pre-purging that occurred due to a previous loss of air, or 10 sec before the end of the pre-purging, or during the safety time, or during normal operation	RED Blink	0.5	2.5	▲△▲△▲△▲△▲△▲△
Lockout for fan motor error	RED, ORANGE blinking inverted	2.5	0.5	▲●▲●▲●▲●▲●▲●
Lockout due to fault with the gas valve control circuit	RED, GREEN blinking inverted	2.5	0.5	▲■▲■▲■▲■▲■▲■
Lockout for eeprom error	ORANGE, GREEN blinking alternately	0.5	0.5	●■●■●■●■●■●■
Lockout due to air pressure switch not closing after a heat request or after a recycle due to flame loss during operation	RED, GREEN slow blinking	2.5	2.5	▲■▲■▲■▲■▲■▲■
Lockout due to air pressure switch already switched to closing of the heat request thermostat or after a recycle due to flame loss during operation	RED, ORANGE slow blinking	2.5	2.5	▲●▲●▲●▲●▲●▲●

Tab. I

Key to layout

ON	OFF	Colour code
▲	△	RED
●	○	ORANGE
■	□	GREEN

Tab. J

### 5.13.3 Checking the gas pressure switch

When the gas pressure switch is open the motor is not powered. If, after a heat request, the gas pressure switch opens, the motor stops and:

- if the gas pressure switch stays open for more than 2 minutes, the fault is displayed by the diagnostic LEDs.
- if the gas pressure switch stays open for less than 2 minutes, the fault is not displayed.
- when the gas pressure switch closes again, the motor is restarted if also the air pressure switch is open.
- when the gas pressure switch is closed the motor is powered for about a second (to acknowledge the signal) and then it is shut off for 2 seconds to be then restarted and start the operation cycle, if the gas pressure switch stays open for more than 2 minutes.

If the gas pressure switch opens during normal flame operation, the motor stops immediately and the gas valves are closed. If the gas pressure switch opens during post-purging or during continuous purging (if set), the motor stops and stays off for the whole time that the gas pressure switch is open and the fault is displayed immediately by the diagnostic LEDs.

### 5.13.4 Checking the air pressure switch

When the burner receives the heat request the air pressure switch is checked and if it is closed (bonded) the motor does not start and after 2 minutes the lockout condition is reached.

If, upon a heat request after the motor starts, the air pressure switch does not close within 15 seconds of pre-purging, the burner reaches the lockout condition.

If there is a loss of air pressure after the first 15 seconds of pre-purging but before the last 10 seconds, a recycle occurs (the pre-purging time starts from when the air pressure switch closes in a stable manner).

If after a recycle after a loss of air pressure there is a new loss, the burner reaches an immediate lockout condition due to lack of air.

If the loss of the air pressure switch occurs in the last 10 seconds of the pre-purging time (before the start of the safety time) the burner reaches an immediate lockout condition due to lack of air.

If there is a loss of the air pressure switch after the opening of the 1st stage valves or during normal operation with flame, the burner reaches the lockout condition within 1s.

The state of the air pressure switch does not influence the post-purging time.

Se If continuous purging is set, the motor is powered even if the air pressure switch is sealed but only in a condition without a heat request or after 2 minutes if the lockout occurred after the heat request.

### 5.13.5 Shut-down test

If the reset button or the remote reset is pressed during operations for more than 5 seconds and less of 10 seconds, ( to not go to the successive menu) the burner switches off, the gas valve closes, the flame goes out and the start-up sequence restarts.

If the switch off test is enabled, the number of repetitions of the start up sequence (see paragraph “**Recycle and limit of repetitions**” on page 24) and the number of possible resets (see paragraph “**External lockout signal (S3)**” on page 25), are reset.

### 5.13.6 Intermittent operation

After 24 hours of continuous operation, the control box starts the automatic switch-off sequence, followed by a restart, in order to check for a possible fault with the flame detector. This automatic switch-off can be fixed at 1 hour, (see paragraph “**Programming menu**” on page 28).

The modification of the parameter setting for intermittent operation takes effect if:

- during the heat request, the switching off test function is enabled;
- there is a flame loss;
- the heat request switches off and then later restarts;
- the control box switches off and restarts;
- the automatic restarting of the intermittent function occurs (1hour/24hours).

### 5.13.7 Recycle and limit of repetitions

The control box allows a recycle function, i.e. complete repetition of the start-up sequence, making up to 3 attempts, in the event the flame failure during operation.

If the flame failure 4 times during operations, this will cause a burner lockout. If there is a new heat request during the recycle, the 3 attempts are reset when the limit thermostat (TL) switches.

By disconnecting the power supply, when a new heat request occurs (power supply is applied to the burner) all possible attempts at re-ignition are reset (maximum 3).

### 5.13.8 Presence of an extraneous light or parasite flame

The presence of a parasite flame or extraneous light can be detected in the stand-by state after a heat request.

If the presence of a flame or extraneous light is detected also in the “t2” stage, the motor does not start until the flame signal has disappeared or until lockout has been reached.

If, after the fan motor starts, during the pre-purging, an extraneous light or parasite flame is detected, the burner reaches the lockout condition in 1 second.

If, during the recycle due to flame disappearance while operating and the consequent repetition of the start-up sequence, the parasite flame or the extraneous light is detected before the motor starts, the 25 seconds control countdown starts (for checking for the presence of the parasite flame or the extraneous light) otherwise the lockout occurs within 1 second.

The fault is indicated by the blinking LED (see paragraph “**Fault diagnostics - lockouts**” on page 23).

When the heat request is finished, if the parasite flame stays on the burner reaches the lockout condition due to parasite flame after 25 seconds (regardless of the presence or otherwise of the post-purging or the continuous purging).

The parasite flame control is active even when there is a fault with the mains voltage, the frequency, the internal voltage, the condition with gas pressure switch open.

The parasite flame control is not active only in lockout conditions.

### 5.13.9 Duration of ignition transformer discharge

The spark ignition is present during all safety time.



WARNING

In the event of continuous recycling or heat requests that are close together, the maximum allowed number of cycle repetitions for the ignition transformer is one every minute.

### 5.13.10 Reset by button and remotely of the burner

The burner can be released by pressing, for at least 0.4 seconds, the reset button integrated in the control box and the unlocking occurs only when the button is released.

The burner can also be reset using an external button (remote reset) connected to the R terminals (see RS electric diagram) on the burner pressing for at least 0.8 seconds.



WARNING

If the reset button is pressed for more than 2 seconds, the control box goes into visual diagnostic mode and the indicator LED begins to blink (see 'Fault diagnostics - lockouts' a pag. 23).

### 5.13.11 Protection reset

The burner can be reset only 5 times consecutively, then power supply has to be disconnected for a new 5 reset possibilities. The burner can only be reset if power supply is applied to the control box.

### 5.13.12 Reset button/Remote reset fault

If the reset button is faulty or is kept pressed for more than 60 seconds, the fault is indicated by the blinking of the LED (see paragraph "Fault diagnostics - lockouts" on page 23) as long as it is present.

This fault is merely a visualisation.

- If the fault is detected during pre-purging or safety time, the burner does not stop (the start-up sequence will continue).
- If the fault is detected during operation, the burner does stop and stays stopped with the fault signal active.
- If the fault is detected during a lockout, the fault is not signalled and the burner cannot be reset. When the fault disappears, the LED stops blinking.

### 5.13.13 External lockout signal (S3)

The burner is equipped with an external locking signal function, i.e. to signal (together with the integrated reset button) a burner locking alarm.

The control box provides a command of an external lamp using the S3 output (230Vac-0.5Amp max).

### 5.13.14 Hour counter function (B4)

The burner has an hour counter function for the duration of the opening of the gas valve is open and therefore fuel consumption. The control box provides control of an external hour counter through the Hour\_Counter output (230V AC-0.1Amp max.) of the control box connected to pin B4.

### 5.13.15 Monitoring the power supply voltage

The control box automatically measures the mains voltage.

If the voltage is less than 160V or more than 280V, the burner stops, interrupts the operating cycle and remains in stand-by, signalling a fault. The fault is indicated by way of the blinking LED (see paragraph "Fault diagnostics - lockouts" on page 23).

The burner restarts when the voltage exceeds approx. 170V or if it goes below 270V.

- If the fault is detected with flame operation, the valve is immediately closed and the motor stops.
- If the fault is detected during pre-purging, the motor stops.
- If when the main power supply switch is closed or after there has been no power, the mains voltage stays within the intermediate values (160-170V or 270-280V) the burner does not start.
- If the burner is in lockout, the mains voltage is monitored but is not signalled in that there is a lock-out signal.

During the ignition time the mains voltage monitoring is deactivated.

### 5.13.16 Frequency supply error

The control box automatically detects the value of the frequency of the main supply in the range of 50 - 60 Hz, in both cases working times are verified. The fault is indicated by way of the blinking LED (see paragraph "Fault diagnostics - lockouts" on page 23).

- If the fault is detected before heat request the burner does not start.
- If the fault is detected during the pre-purging, the burner remains in purge condition and the fault is appropriately signalled.
- The fault is not detected during normal running, the burner remains in this state. When the fault disappears, the burner restarts.

### 5.13.17 Internal voltage fault

The control box automatically detects if the internal voltage works correctly. The fault is indicated by way of the blinking LED (see paragraph "Fault diagnostics - lockouts" on page 23).

- If the fault is detected during the initialisation check time, the burner does not start.
- If the fault is detected after a lockout the burner does not start.
- If the fault is detected after a shut-down test, the burner does not start.
- The fault is not detected during normal running, the burner remains in this state. When the fault disappears, the burner restarts.

**5.13.18 Checking the fan motor**

The control box automatically detects the presence of the fan motor and, in the event of a fault, it performs a lockout. The lockout is indicated by the blinking of the LED (see paragraph “**Fault diagnostics - lockouts**” on page 23).

**5.13.19 Checking the faults of the gas valve and the motor**

The control box detects the presence of a fault in the valve and motor controls, the fault is indicated by the blinking LED (see paragraph “**Fault diagnostics - lockouts**” on page 23):

- if the anomaly is detected during the initialisation, the burner goes into lockout.
- if the anomaly is detected during the pre-purging, the burner goes into lockout.
- During a recycling, if the fault is detected, the burner does not start and goes into lockout.

The fault is not detected if the burner is in lockout.

The sealing of the contact of the relay inside the motor's control box is intercepted if the gas pressure switch is closed and the motor is connected to the board.

The closing of the relay contact inside the gas valve control is intercepted only with the motor on.

**5.13.20 EEprom check**

The control box automatically detects if EEprom memory of micro-controller has failed and will perform a lockout. The lockout is indicated by the blinking of the LED (see paragraph “**Fault diagnostics - lockouts**” on page 23).

**5.13.21 Ionisation current**

The recommended minimum for operating the burner is 5 µA. The burner normally supplies a higher current value, so that no check is needed.

In any event, if you want to measure the ionisation current, you need to open the connector (CN1) (Fig. 21) on the red wire and insert a microammeter.

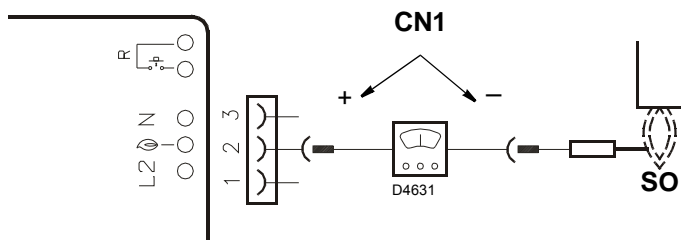

**Fig. 21**

**5.13.22 Post-purging**

Post-purging is a function that allows you to maintain the air purging even after the burner is switched off in the absence of the heat request for a pre-set time.

The burner switches off the flame when the heat request thermostat opens, and the fuel supply to the gas valve stops.

The post-purging function is not performed:

- after a lockout of the motor or valves;
- if the heat request is interrupted during pre-purging.

Post-purging occurs:

- if the heat request is interrupted during the safety time;
- if the heat request is interrupted during normal operation;
- with all types of lockout.

**NOTE:**

If during post-purging there is an extraneous light or a parasite flame the burner goes into lockout after 25 seconds.

If during post-purging there is a new heat request, the post-purging time is halted, the fan motor stops and a new burner operating cycle starts.

**5.13.23 Continuous purging**

Continuous purging is a function that maintains the air ventilation independently of the request for burner ignition.

From the moment when it is set, the motor remains in operation both when the limit thermostat (TL) is not switched over (burner switched off), and when the burner is in lockout.

With the commutation of the limit thermostat (TL) the motor stops for the standby time of 2 seconds, the successive control of the air pressure switch and the start of a new burner operation cycle.

- If during continuous purging when there is no heat request a parasite flame is detected, the motor stays on and a fault is signalled. The burner reaches the lockout condition after 25 seconds.
- If during continuous purging a parasite flame is detected, the motor stays on but if a heat request occurs the motor is switched off, the motor is not started after the standby (2sec) if the parasite flame persists; the burner reaches the lockout condition after 25 seconds. After the lockout has been reset the motor is restarted.
- The motor stays on even in a lockout.
- Continuous purging is interrupted if an internal fault is detected that brings the burner to the lockout condition (eeprom, motor, gas valve).

**5.13.24 Lockout log**

The control box allows the logging of the type and number of lockouts that have occurred and keeps them even without the electrical power supply.

The logs of the lockouts allows you to access the last 10 lockouts (see paragraph “**Programming menu**” on page 28).

Once the programming menu page has been reached by pressing the reset button the last lockout is displayed, pressing 10 times displays the least recent lockout (each time the burner reaches the lockout condition the oldest one is removed).

5 seconds after the last pressing of the buttons, the type of lockout is displayed, see paragraph “**Fault diagnostics - lockouts**” on page 23).

**5.13.25 Logging of burner operating parameters**

The control box allows you to log the operating time of the opening of the gas valve.

In this way it is possible to establish how much fuel has been consumed during the operation.

The frequency of the count is 1 second.

Saving to memory (eeprom) of the data occurs every 30 minutes if the burner is on.

Saving to memory is carried out even if in the previous 30 minutes the control box was operating only for a short period of time.

If the control box is cut off from the mains power supply between one saving and the next (after 30 minutes) the information about this interval is lost.

If in the interval between one saving and the next a lockout is set, there is writing to memory that involves also the logging of the operating hours.

Together with the operating hours also the number of the burner's 1st stage valve openings is saved.

In the menu (see paragraph “**Programming menu**” on page 28) it is possible to independently reset both the operating hours meter and the meter for the number of openings of the 1st stage valve that occurred.

- The number of openings of the 1st stage valve is a maximum of: 16.777.215 (after which it is reset).
- The meter for the number of openings of the first stage valve is a maximum: 65,535 days (after which it is reset).

To display these parameters it is necessary to connect the PC DGT1000 diagnostic software kit.

**5.13.26 Admissible lengths of the external connections to the burner**

Outlet cables of the burner	Identification	Maximum length permitted (metres)
Mains electric power supply	L1 (L), N	20
GAS pressure switch	PG	1
Heat request thermostat	TL (T1,T2)	2
Hour counter	B4	3
External lockout indicator	S3	20
Remote reset	R (RS)	20

**Tab. K**



**WARNING**

In the event of burner applications with remote control commands greater than those indicated in Tab. K, insert the relay command devices (230Vac) with contacts placed near or not more than the maximum indicated lengths.

**5.13.27 Long pre-purging**

If a long pre-purging is enabled, an initial pre-purging of 1 min and 20 sec beyond the default pre-purging time (40 sec) is carried out.

In recycles due to flame loss when operating, the long pre-purging is not carried out but only the pre-purging with the default time (40 sec).

If there is a loss of air pressure during the long pre-purging, the recycle involves a repetition of the pre-purging that in this case is 1 min and 20 sec added to 40 sec.

**5.14 Programming menu**

**5.14.1 General notes**

The programming menu can be accessed via the integrated reset button, or by remote reset during OPERATION and in STANDBY.

If in page menu the reset or remote reset button is not pressed within 10 seconds the page will be automatically be exited and there will be a green LED blinking for the time set.

If the number of presses on the reset or remote reset button exceeds the maximum allowable, the value that stays in memory will be the maximum one.

If the reset or remote reset button is pressed for more than 60 seconds, a button error will be displayed and the control box will restart.

**5.14.2 Block diagram for entering the menu**

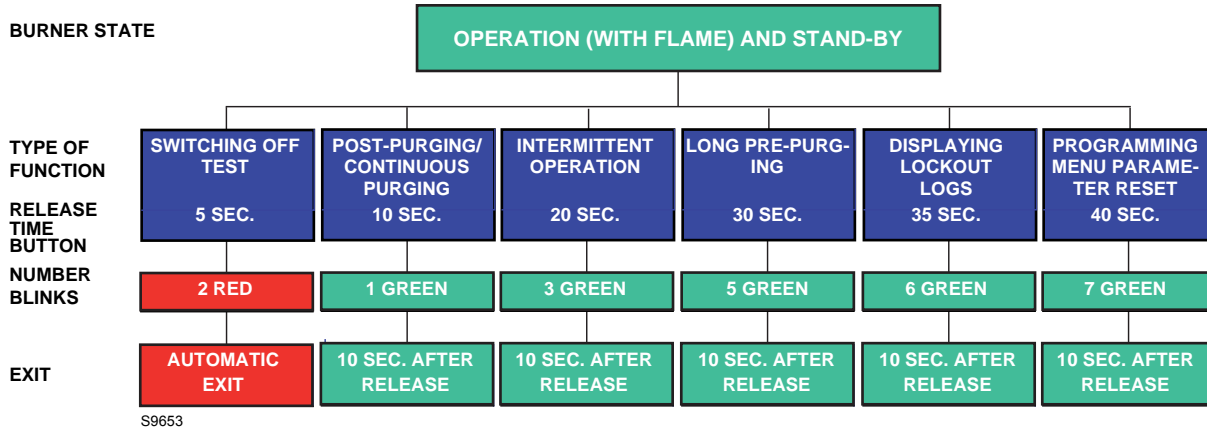

**Fig. 22**

Function	Button release time	No. of blinks of the led per menu page	No. of pressings of the reset button	No. of blinks of the LED (green)	Quitting the menu
Switching off test	5s ≤ t < 10s	2 blinks RED	/ none	/ none	Automatic, at the end of the blink
Post-purging/Continuous purging	10s ≤ t < 15s	1 GREEN blink	1 = 1 minute 2 = 2 minutes 3 = 3 minutes 4 = 4 minutes 5 = 5 minutes 6 = 6 minutes 7 = continuous purging 8 = 0 m (deactivated) (default)	1 blink 2 blinks 3 blinks 4 blinks 5 blinks 6 blinks 7 blinks 8 blinks	10 sec. after the release of the button
Intermittent operation	20s ≤ t < 25s	3 blinks GREEN	1 = 1 hour 2 = 24 hours (default)	1 blink 2 blinks	10 sec. after the release of the button
Pre-purging long	30s ≤ t < 35s	5 blinks GREEN	1 = activated 2 = deactivated (default)	1 blink 2 blinks	10 sec. after the release of the button
Display lockout logs	35s ≤ t < 40s	6 blinks GREEN	1 = last lockout 2 = 9th lockout 3 = 8th lockout 4 = 7th lockout 5 = 6th lockout 6 = 5th lockout 7 = 4th lockout 8 = 3rd lockout 9 = 2nd lockout 10 = less recent lockout	Displaying the type of lockout according to Tab. I	10 sec after the release of the button (if at level 1). When at level 2, 10 sec after the display of the type of lockout or else pressing the button again before 10 sec you return to level 1 from where, 10 seconds after nothing has been done to the buttons, you exit the menu
Parameter reset programming menu	40s ≤ t < 45s	7 blinks GREEN	1 = reset of the lockout logs 2 = reset of the no. of lockouts 3 = reset of hours of operation 4 = reset of the no. of heat requests 5 = restoration of default values of the menu parameters	/	10 sec. after the release of the button

**Tab. L**

### 5.14.3 Shut-down test

#### Sequence for shut-down test programming

- Programming allowed in OPERATING mode and in STAND-BY
- Press the button for 5 sec.  $\leq t < 10$  sec.
- The RED LED blinks twice (0.2 sec. ON; 0.2 sec. OFF)
- Release the button
- The burner will initialise a shut-down followed by a restart

After shut-down, the burner restarts automatically and the no. of attempts of recycle are restored.

At the exit of shut-down test page menu there are no blinking led.

### 5.14.4 Post-purging and continuous purging

The post-purging time can be set for a maximum of **6 minutes**, proceeding as follows:

#### Programming sequence

- Programming allowed in OPERATING mode and in STAND-BY.
- Press the button for 10 sec.  $\leq t < 15$  sec.
- GREEN LED blinking 1 time
- Release the button
- GREEN LED OFF
- Press the button 1 - 6 times (\*) = 1 - 6 minutes  
7 times = continuous purging
- GREEN LED ON and OFF every time press and release
- After 10 sec., the GREEN LED will blink for the number of times programmed (0.5 sec. ON; 0.5 sec. OFF)

#### Disabling sequence

- Reset allowed in OPERATING mode and in STAND-BY.
- Press the button for 10 sec.  $\leq t < 15$  sec.
- GREEN LED blinking 1 time
- Release the button
- GREEN LED OFF
- Press the button 8 times (\*)
- GREEN LED ON and OFF every time press and release
- After 10 sec. the GREEN LED blinks for 8 times (0.5s ON; 0.5s OFF)

**If heat request stops during programming of post-purging function, the exit menu occurs without saving the setting value.**

**If heat request stops during the LED blinking occur exit menu, but the setting value is stored.**

### 5.14.5 Intermittent operation

#### Sequence for enable/disable

- Programming allowed in OPERATING mode and in STAND-BY
- Press the button for 20 sec.  $\leq t < 25$  sec.
- GREEN led blinking 3 times
- Release the button
- GREEN led OFF
- Press the button 1 time to enable a shut-down every hour (\*)
- Press the button 2 times to enable a shut-down every 24 hours (\*)
- GREEN led ON and OFF every time press and release
- After 10 sec., the GREEN LED will blink for the number of times programmed (0.5 sec. ON; 0.5 sec. OFF).

The modification of the parameter setting for Intermittent operation takes effect:

- after the next heat request by the thermostat (HT)
- after the activation of a switch-off test
- after flame disappearance during operation
- after disconnecting and reconnecting the electrical supply

### 5.14.6 Setting the long pre-purging

The control box allows you to set the long pre-purging, see paragraph “**Block diagram for entering the menu**” on page 28.

#### Sequence for setting a long pre-purging

- Programming allowed in OPERATING mode and in STAND-BY.
- Press the button for 30 sec.  $\leq t < 35$  sec.
- GREEN led blinking 5 times
- Release the button.
- GREEN LED OFF
- Press the button 1 time to enable the long pre-purging (\*)
- Press the button 2 times to disable the long pre-purging (\*)
- GREEN LED ON and OFF every time press and release
- After 10 sec., the GREEN LED will blink for the number of times programmed (0.5 sec. ON; 0.5 sec. OFF).

### 5.14.7 Displaying the lockout log

The control box allows you to display the last 10 lockouts that occurred and were logged, accessing the "Programming menu" on page 28.

Access to this page is possible both in STAND-BY, as well as in the OPERATING status.

#### Display sequence of the last lockout that occurred

- Keep the button pressed for 35 sec. =  $t < 40$  sec.
- The GREEN LED blinks 6 times.
- Release the button.
- Displaying the type of lockout memorised for 10 sec.

The time displaying the type of lockout can be extended by repressing the reset button during the display of the lockout (the lockout display continues for another 10s).

### 5.14.8 Resetting the programming menu parameters and the lockout log

The control box allows you to reset the log and the number of lockouts, the operating hours, the number of ignitions and recover the menu's default, see paragraph "**Block diagram for entering the menu**" on page 28.

#### Sequence for setting and restoring the parameters

- Programming allowed in OPERATING mode and in STAND-BY.
- Press the button for 40 sec.  $\leq t < 45$  sec.
- The GREEN LED blinks 7 times.
- Release the button.
- GREEN LED OFF
- Press the button 1 time to reset the lockout log (\*)
- Press the button 2 times to reset the number of lockouts (\*)
- Press the button 3 times to reset the number of hours operating with flame (\*)
- Press the button 4 times to reset the number of heat requests (\*)
- Press the button 5 times to reset all the default values of the parameters of the PROGRAMMING MENU (\*)
- GREEN LED ON and OFF every time pressed and released
- After 10 sec., the GREEN LED will blink for the number of times programmed (0.5 sec. ON; 0.5 sec. OFF).

#### NOTE:

(\*) Always wait 1 sec. with each pressing and release of the button to ensure the command is logged correctly.



**5.15 Lockout types**

Whenever a lockout occurs, the control box shows the reasons for the fault (and the reasons can be identified by the reset button colour).

The sequence of pulses issued by the control box of the LED in the reset button identifies the possible types of fault, which are listed in the table below:

Lockout description	Lockout time	Led colour	Probable cause
Presence of parasite flame during stand-by	After 25 seconds	▲▲▲▲	- presence of a false flame after heat request or during post-purging
Detection of parasite flame during pre-purging	After 1 second	▲▲▲▲	- presence of false flame signal during pre-purging
The flame is not detected after the safety time	3 seconds after the activation of the gas valve	▲▲▲▲	- ionisation probe faulty or not connected - gas valve - faulty ignition transformer - badly regulated burner
Flame failure during operation	After 3 recycles	▲▲▲▲	- burner not calibrated correctly - ionisation probe faulty
Fan motor error	Immediate	▲●▲●	- faulty fan motor - fan motor not connected
Fault with the gas valve control circuit	Immediate	▲■▲■	- gas valve - internal control circuit of the 1st stage gas valve faulty
Eeprom error	Immediate	●■●■	- faulty internal memory
Lockout due to air pressure switch not closing after a heat request or after a recycle due to flame loss during operation	After 15 seconds	▲■▲■	- the air pressure is too low, (the head has been poorly adjusted) - The air pressure switch is defective: change it
Lockout for loss of air pressure or after repetition of the pre-purging due to loss of air, or 10 sec before the end of the pre-purging, or during the safety time, or during normal operation	After 1 second	▲▲▲▲	- the air pressure is too low, (the head has been poorly adjusted) - the air pressure switch is defective: change it
Lockout due to air pressure switch already switched to closing of the heat request thermostat or after a recycle due to flame loss during operation	After 120 seconds	▲●▲●	- the air pressure switch is changed over to the operational position, change the pressure switch - the fan motor continues to be powered, check the lockout of the flame control

**Tab. M**

Blink frequency of the reset button for status indication (see paragraph “**Fault diagnostics - lockouts**” on page 23).



To reset the control box after visual diagnostics have been displayed, you must press the reset button.



In the event the burner stops, in order to prevent any damage to the installation, do not unblock the burner more than twice in a row. If the burner locks out for a third time, contact the customer service.



In the event there are further lockouts or faults with the burner, the maintenance interventions must only be carried out by qualified, authorised personnel, in accordance with the contents of this manual and in compliance with the standards and regulations of current laws.

**6 Start-up, calibration and operation of the burner**

**6.1 Notes on safety for the first start-up**



The first start-up of the burner must be carried out by qualified personnel, as indicated in this manual and in compliance with the standards and regulations of the laws in force.



Check the correct working of the adjustment, command and safety devices.



Refer to paragraph "Safety test - with gas ball valve closed" on page 33 before the first start-up.

**6.2 Adjustments prior to ignition**

- Check the adjustment of the head as shown in pag. 15.
- Check the adjustment of the air damper as shown in pag. 16.
- Slowly open the manual valves situated upstream from the gas train.
- Adjust the air pressure switch (Fig. 23) to the start of the scale.

- Purge the air from the gas line.  
We recommend using a plastic tube routed outside the building and to purge air until gas is smelt.



Before starting up the burner, it is good practice to adjust the gas train so that ignition takes place in conditions of maximum safety, i.e. with gas delivery at the minimum.

**6.3 Combustion adjustment**

In conformity with EN 676 the application of the burner on the boiler, adjustment and testing must be carried out observing the instruction manual of the boiler, including verification of the CO

and CO<sub>2</sub> concentration in the flue gases, their temperatures and the average temperature of the water in the boiler.

It is advisable to set the burner according to the type of gas used and following the indications in Tab. N.

EN 676		Air excess: max. output. $\lambda \leq 1.2$ – min. output $\lambda \leq 1.3$			
GAS	Theoretical max CO <sub>2</sub> 0 % O <sub>2</sub>	Setting CO <sub>2</sub> %		CO mg/kWh	NO <sub>x</sub> mg/kWh
		$\lambda = 1.2$	$\lambda = 1.3$		
G 20	11.7	9.7	9.0	≤ 100	≤ 170
G 25	11.5	9.5	8.8	≤ 100	≤ 170
G 30	14.0	11.6	10.7	≤ 100	≤ 230
G 31	13.7	11.4	10.5	≤ 100	≤ 230

Tab. N

**6.4 Air pressure switch**

Adjust the air pressure switch (Fig. 23) after performing all other burner adjustments with the air pressure switch set to the start of the scale. With the burner function at the required output, turn the knob slowly in a clockwise direction until burner lockout.

Then turn the knob anticlockwise to an extent that is around 20% of the adjusted value and then check that the burner starts up properly.

If the burner locks out again turn the knob slightly in an anticlockwise direction.



In conformity with the standard, the air pressure switch must prevent the air pressure falling below 80% of the adjusted value and the CO in the flue gases exceeding 1% (10,000 ppm).

To check this, insert a combustion analyser in the flue, slowly reduce the burner air setting (for example with a piece of cardboard) and verify that the burner locks out before the CO value in the flue gases exceeds 1%.

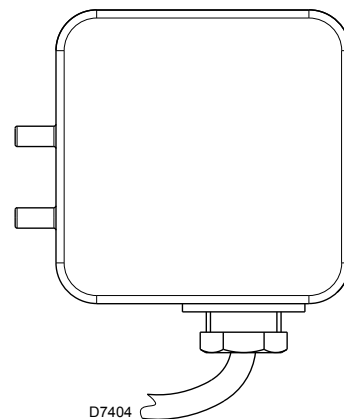

Fig. 23

## 7 Maintenance

### 7.1 Notes on safety for the maintenance

The periodic maintenance is essential for the good operation, safety, yield and duration of the burner.

It allows you to reduce consumption and polluting emissions and to keep the product in a reliable state over time.



The maintenance interventions and the calibration of the burner must only be carried out by qualified, authorised personnel, in accordance with the contents of this manual and in compliance with the standards and regulations of current laws.

Before carrying out any maintenance, cleaning or checking operations:



Disconnect the electrical supply from the burner by means of the main system switch.



Turn off the fuel interception tap.



Wait for the components in contact with heat sources to cool down completely.

### 7.2 Maintenance programme

#### 7.2.1 Maintenance frequency



The gas combustion system should be checked at least once a year by a representative of the manufacturer or another specialised technician.

#### 7.2.2 Safety test - with gas ball valve closed

It is fundamental to ensure the correct execution of the electrical connections between the gas solenoid valves and the burner to perform safely the commissioning.

For this purpose, after checking that the connections have been carried out in accordance with the burner's electrical diagrams, an ignition cycle with closed gas ball valve -dry test- must be performed.

- 1 The manual ball gas valve must be closed
- 2 The electrical contacts of the burner limit switch need to be closed
- 3 Ensures closed the contact of the low gas pressure switch
- 4 Make a trial for burner ignition.

The start-up cycle must be as follows:

- Starting the fan for pre-ventilation
- Performing the gas valve seal control, if provided
- Completion of pre-ventilation
- Arrival of the ignition point
- Power supply of the ignition transformer
- Electrical Supply of solenoid gas valves

Since the manual gas ball valve is closed, the burner will not light up and its control box will go to a safety lockout condition.

The actual electrical supply of the solenoid gas valves can be verified by inserting a tester. Some valves are equipped with light signals (or close/open position indicator) that turn on at the same time as their power supply.



**IF THE ELECTRICAL SUPPLY OF THE GAS VALVES OCCURS AT UNEXPECTED TIMES, DO NOT OPEN MANUAL GAS BALL VALVE, SWITCH OFF POWER LINE; CHECK THE WIRES; CORRECT THE ERRORS AND REPEAT THE COMPLETE TEST.**

#### 7.2.3 Checking and cleaning



The operator must use the required equipment during maintenance.

##### Combustion

Check there are no occlusions or obstructions in the fuel supply or return lines, in the air suction areas, and in the combustion product waste pipe.

Carry out an analysis of the combustion flue gases.

Significant differences with respect to the previous measurements indicate the points where most care should be exercised during maintenance.

##### Combustion head

Check that the positioning of the combustion head is correct and that it is properly fixed to the boiler.

Open the burner and make sure that all components of the combustion head are in good condition, not deformed by the high temperatures, free of impurities from the surroundings and correctly positioned.

##### Burner

Check that there are not excess wear or loosen screws.  
Clean the outside of the burner.

##### Fan

Check that the air damper is positioned correctly.  
Check to make sure that no dust has accumulated inside the fan or on its blades, as this condition will cause a reduction in the air flow rate and provoke polluting combustion.

##### Boiler

Clean the boiler as indicated in its accompanying instructions in order to maintain all the original combustion characteristics intact, especially the flue gas temperature and combustion chamber pressure.

### Gas train

Check that the gas train is suited to the burner capacity, the type of gas used and the mains gas pressure.

### Electrode-probe

Checking the proper positioning of the ionisation probe and electrode as shown in Fig. 12 on pag. 16.

### Pressure switches

Check that the air pressure switch and the gas pressure switch are set correctly.

### Gas leaks

Make sure that there are no gas leaks on the pipe between the gas meter and the burner.

### Gas filter

Change the gas filter when it is dirty.

### Combustion

If the combustion values measured before starting maintenance do not comply with applicable legislation or do not indicate efficient combustion, consult the Tab. N on pag. 32 or contact our Technical Support Service to implement the necessary adjustments.

Leave the burner working without interruptions for 10 min. and set rightly all the components stated in this manual.

Then carry out a combustion check verifying:

- Percentage of CO<sub>2</sub> (%);
- CO content (ppm)
- NOx content (ppm)
- Ionisation current (µA)
- Smoke temperature at the flue

### 7.2.4 Safety components

The safety components must be replaced at the end of their life cycle indicated in Tab. O. The specified life cycles do not refer to the warranty terms indicated in the delivery or payment conditions.

Safety component	Life cycle
Flame control	10 years or 250,000 operation cycles
Flame sensor	10 years or 250,000 operation cycles
Gas valves (solenoid)	10 years or 250,000 operation cycles
Pressure switches	10 years or 250,000 operation cycles
Pressure adjuster	15 years
Servomotor (electronic cam) (if present)	10 years or 250,000 operation cycles
Oil valve (solenoid)(if present)	10 years or 250,000 operation cycles
Oil regulator (if present)	10 years or 250,000 operation cycles
Oil pipes/ couplings (metallic) (if present)	10 years
Flexible hoses (if present)	5 years or 30,000 pressurised cycles
Fan impeller	10 years or 500,000 start-ups

Tab. O

### 7.3 Opening the burner



Disconnect the electrical supply from the burner by means of the main system switch.



Turn off the fuel interception tap.



Wait for the components in contact with heat sources to cool down completely.

If maintenance of the combustion head is required, refer to the instructions given in "Operating position" on page 14.

For accessing to the interior of the burner, loosen the screws that secure the cover and proceed with the maintenance operation.



### Operating safety hazards

Repairs to the following components may only be carried out by the respective manufacturers or by personnel instructed by them:

- fan motor
- actuator
- air damper servomotor
- electromagnetic valves
- burner programmer

### Check the operation

- Start-up of the burner with a sequence of functions (see chapter "Operating programme" on page 21)
- Ignition device
- Air pressure switch
- Flame monitoring
- Tightness test of components to the passage of fuel



After carrying out maintenance, cleaning or checking operations, reassemble the cover and all the safety and protection devices of the burner.

**8** Faults - Possible causes - Solutions

Here below you can find some causes and the possible solutions for some problems that could cause a failure to start or a bad working of the burner

In most cases, an operation irregularity leads to the lighting up of the signal inside the reset button of the control box (Fig. 4 on pag. 10).

When lockout lamp lights the burner will attempt to light only after pushing the reset button. After this if the burner functions correctly, the lockout can be attributed to a temporary fault.

However, if lockout continues, you must determine the cause of the problem and take the action illustrated in Tab. P and Tab. Q.



In the event the burner stops, in order to prevent any damage to the installation, do not unblock the burner more than twice in a row. If the burner locks out for a third time, contact the customer service.



In the event there are further lockouts or faults with the burner, the maintenance interventions must only be carried out by qualified, authorised personnel, in accordance with the contents of this manual and in compliance with the standards and regulations of current laws.

**8.1** Start-up problems

Faults	Possible Causes	Solution
The burner does not start when the limit thermostat closes (TL).	Lack of electrical supply.	Check presence of voltage in the L1-N clamps of the 7 pin plug. Check the conditions of the fuses. Check that safety thermostat (TS) is not in lockout.
	Lack of gas.	Check the manual cock opening. Check that the valves change over to the opening position and there are not short circuits.
	The gas pressure switch does not close its contact.	Adjust them.
	The connections in the control box are wrongly inserted.	Check and connect completely all the plugs.
	The air pressure switch is changed over to the operational position.	Replace the pressure switch.
	The actuator is faulty.	Check the connection or replace the actuator.
Burner runs normally in pre-purging and ignition cycle and locks out after the safety time.	The phase-neutral connection is inverted.	Invert them.
	The earth connection lacks or is inefficient.	Make the earth connection efficient.
	The ionisation probe is earthed or not in contact with the flame, or its wiring to the control box is broken, or there is a fault on its insulation to the earth.	Check the right position and if necessary set it according to the instructions of this manual. Reset the electrical connection. Replace the faulty connection.
Burner starts with an ignition delay.	The ignition electrodes is wrongly positioned.	Adjust it according to the instructions of this manual.
	Air output is too high.	Set the air output according to the instructions of this manual.
	Valve brake is too close with insufficient gas output.	Adjust it.
The burner locks out after the pre-purge phase due to flame-failure.	The solenoid valves is passing too little gas.	Check the pressure in the network and/or adjust the solenoid valve according to the instructions of this manual.
	The solenoid valves are defective.	Change them.
	The ignition arc is irregular or has failed.	Check the right insertion of the connectors. Check the right position of the electrode according to the instructions of this manual.
	The pipe has not been purged from the air.	Carry out a complete breathing of the line of gas-supply.

<b>Faults</b>	<b>Possible Causes</b>	<b>Solution</b>
The burner locks out during the pre-purge phase.	The air pressure switch does not change over to the operational position.	The pressure switch is faulty, change it. The air pressure is too low, (the head is bad adjusted).
	The flame exists.	Faulty valves: replace them.
The burner continues to repeat the starting cycle without going on lockout.	The gas pressure in the gas-mains lies very close to the value to which the gas pressure switch has been set.	Lower and set the pressure switch.
	The sudden drop in pressure when the valve is opened provokes the opening of the pressure switch itself, so the valve closes again immediately and the motor stops.	
	The pressure then starts to increase again, the pressure switch closes, the start-up cycle begins again and so on.	

**Tab. P**

**8.2 Operating faults**

<b>Fault</b>	<b>Possible Causes</b>	<b>Solution</b>
The burner locks out during operation.	Earth probe.	Check the right position and if necessary set it according to the instructions of this manual. Clean or replace the ionisation probe.
	The flame disappears 4 times.	Check the gas pressure in the network and/or adjust the solenoid valve according to the instructions of this manual.
	Air pressure switch opening.	The air pressure is too low, (the head is bad adjusted). The air pressure switch is faulty: change it.
Burner shut down.	Gas pressure switch opening.	Check the pressure in the network and/or adjust the solenoid valve according to the instructions of this manual.

**Tab. Q**

**A Appendix - Accessories****Long head kit**

Burner	Standard length (mm)	Long head length (mm)	Code
RIELLO 40 GS3	100	125	3000820

**GPL kit**

Burner	Code
RIELLO 40 GS3	3000881

**Town gas kit**

Burner	Code
RIELLO 40 GS3	3000888

**Remote reset kit for control box**

Burner	Code
RIELLO 40 GS3	3002750

**Air suction kit**

Burner	Code
RIELLO 40 GS3	20027571

**Faults Kit**

Burner	Code
RIELLO 40 GS3	3001180

**7 pin plug kit**

Burner	Code
RIELLO 40 GS3	3000945

**Gas trains in compliance with EN 676**

Please refer to manual.



ATTENZIONE

The installer is responsible for the addition of any safety device not foreseen in this manual.

---

**RIELLO**

RIELLO S.p.A.  
I-37045 Legnago (VR)  
Tel.: +39.0442.630111  
[http:// www.riello.it](http://www.riello.it)  
[http:// www.riello.com](http://www.riello.com)