

Silavent

Green Line HRX2

Mechanical Ventilation with Heat Recovery appliance

Installation and Operating Instructions

Models: HRX2-S, HRX2-B, HRX2-FP, HRX2-BFP

These instructions must be given to the householder



DO NOT SWITCH OFF THE UNIT – it is designed to run continuously. If the unit is switched off, indoor pollutants and moisture levels may increase which could endanger your health or damage your home.

It is important to follow the advice in this manual and correctly maintain the system to ensure a healthy indoor environment.

Have you considered an extended warranty package, for extra peace of mind?

Polypipe offer extended warranty options. Please refer to page 22 for further information or call 08443 715523.

Warnings & Safety Information

IMPORTANT!

PLEASE READ THESE INSTRUCTIONS CAREFULLY BEFORE COMMENCING INSTALLATION

1. Do not install this appliance in areas where the following may be present or occur:
 - Excessive oil or a grease laden atmosphere
 - Corrosive or flammable gases, liquids or vapours
 - Be subject to direct water spray
 - Ambient temperatures higher than 50°C and lower than -25°C
 - Possible obstructions that may hinder access or removal of the unit
 2. This appliance is not intended for use by young children or infirm persons without adequate supervision.
 3. All wiring must be in accordance with prevailing national regulations, for example the current IEE Wiring Regulations BS7671. The electrical installation should be inspected and tested by a suitably qualified person after completion.
 4. The appliance should be provided with a local double pole fused spur fitted with a 3Amp fuse and a minimum contact separation of at least 3mm.
 5. Ensure that the mains supply (Voltage and Frequency) complies with the rating label.
 6. This appliance must be earthed.
 7. When installing the appliance, care should be taken not to damage any hidden utilities.
 8. The installer is responsible for the installation and electrical connection of the HRX2 system on site. It is the responsibility of the installer to ensure that the equipment is safely and securely installed and left only when electrically and mechanically safe.
 9. All regulations and requirements must be strictly followed to prevent hazards to life and property, both during and after installation and any subsequent servicing or maintenance.
 10. In dwellings where it is intended to install open-flue appliances and extract ventilation, the combustion appliance should be able to operate safely, whether or not the fans are running. A way of showing compliance with The Building Regulations in these circumstances would be to follow the installation guidance shown below, and to show by tests that combustion appliances operate safely, whether or not the fans are running.
 - A. For gas appliances: where a room contains an open-flue appliance, the extract rate should not exceed 20l/s (72m³/h).
 - B. For oil appliances: where a room contains an open-flue appliance, the extract rate should be limited to 40l/s (144m³/h) for an appliance with a pressure jet burner and 20l/s (72m³/h) for an appliance with a vaporising burner.
 - C. For solid fuel appliances: avoid installing extract ventilation in the same room.
- Further reference should be made to Approved Document J of The Building Regulations.
11. A condensate drain should be installed from the appliance to an appropriate drain location. Polypipe recommend Domus 297 condensate drain kit.
 12. The condensate drain and associated pipe work must be cleared of debris prior to commissioning and insulated where it passes through unheated spaces and voids.
 13. This appliance should not be connected to a tumble dryer or cooker hood.
 14. The supply air must be drawn from the exterior of the property.
 15. The extract air must be expelled to the exterior of the property.
 16. It is recommended that the two external terminals or grilles are set at least 2m apart.
 17. The supply and exhaust ceiling valves should be positioned at least 300mm from internal walls to allow airflow measuring equipment to fit correctly over the valves.
 18. Ducting should be insulated with Domus Thermal duct insulation where it passes through unheated spaces and voids (e.g. loft spaces) to reduce the possibility of condensation forming and heat loss.

Contents

Warnings & Safety Information

1.0	General description	Page 4
1.1	Overview	Page 4
1.2	Physical specification	Page 6
1.3	Optional main features	Page 6
1.3.1	Summer bypass	Page 6
1.3.2	Frost protection	Page 6
2.0	Installation	Page 7
2.1	Overview	Page 7
2.2	Preparation	Page 7
2.3	Installing the frost protection sensor	Page 9
2.4	Wall/surface fitting the HRX2 appliance	Page 9
2.5	Fitting the bypass valve	Page 10
2.6	Fitting the wiring centre	Page 11
2.7	Fitting the condensate drain kit	Page 12
2.8	Ducting guidelines	Page 12
3.0	Electrical	Page 14
3.1	Overview	Page 14
3.2	Frost protection only, wiring-centre fan connections	Page 14
4.0	Commissioning	Page 15
4.1	Overview	Page 15
4.2	System balancing	Page 15
	HRX2-S wiring diagram	Page 16
	HRX2-B wiring diagram	Page 17
	HRX2-FP wiring diagram	Page 18
	HRX2-BFP wiring diagram	Page 19
	ANC108A, ANC802A, ANC846A, ANC808A, ANC813A & ELE150R wiring diagrams	Page 20
5.0	Maintenance	Page 21
5.1	Routine maintenance	Page 21
6.0	Warranty	Page 22

1.0 General description (all models)

1.1 Overview

- 1.1.1 The **Silavent HRX2** appliance is a key part of a whole house ventilation system specifically designed to improve indoor air quality in dwellings. The system is designed to provide measured amounts of filtered, fresh air to living areas while constantly removing polluted, stale air from bathing, cooking and washing areas at the same gentle rate. Any available heat in the outgoing stale air is recovered by a built-in heat exchanger and used to pre-warm the fresh supply air.
- 1.1.2 A manual boost switch is provided to increase the ventilation rate, e.g. when cooking or showering thereby maintaining a comfortable indoor environment.



- 1.1.3 The boost facility can also be triggered from a lighting circuit or by a range of sensors, including humidity control and movement detection (supplied separately – see section 1.1.8)
- 1.1.4 The G3/EU3 filters in the appliance ensure that the fresh supply air is clean as it enters the home. Additionally, the stale extract air is filtered to protect the heat exchanger from unwanted contamination. These filters have to be cleaned regularly, depending on the levels of pollution. The filters should be replaced when they start to show visible signs of wear.
- 1.1.5 This product is listed in SAP Appendix Q, therefore, part of the installation process requires that an installation checklist is completed and submitted to the Building Control Body (BCB). Blank checklists are available at www.sap-appendixq.org.uk
- 1.1.6 Pack includes:
- Silavent HRX2 appliance
 - Two duct connection plates and a bag of 18 fixing screws.
 - Wiring centre
 - Ventilation control switch - either one gang boost control (models HRX2-S, HRX2-FP) or two gang combined boost and summer bypass control (models HRX2-B, HRX2-BFP)
 - Installation and operating instructions manual and 'householder-instruction cover' with fixings
- 1.1.7 Ancillary items required:
- Domus Ø150mm rigid duct system (Domus 220mm x 90mm rectangular can be used in restricted spaces), or Domus radial duct system (see 2.8)
 - Optional Domus HRX2-CK1 'soft' duct connection kit (see 2.8.3)
 - Domus Thermal duct insulation (see 2.8.4)
 - Domus 297 condensate drainage kit (see 2.7)
- 1.1.8 Ancillary options (see page 20)
- Silavent adjustable overrun timer, code ANC108A
 - Silavent humidity control (with adjustable overrun timer), code ANC802A
 - Silavent humidity control (with adjustable overrun timer and remote sensor), code ANC846A
 - Silavent humidity control (with adjustable overrun timer and manual override with neon indicator), code ANC808A
 - Silavent PIR movement control (with adjustable overrun timer), code ANC813A
 - Silavent 6-Switched live backfeed protected junction box, code ELE150R

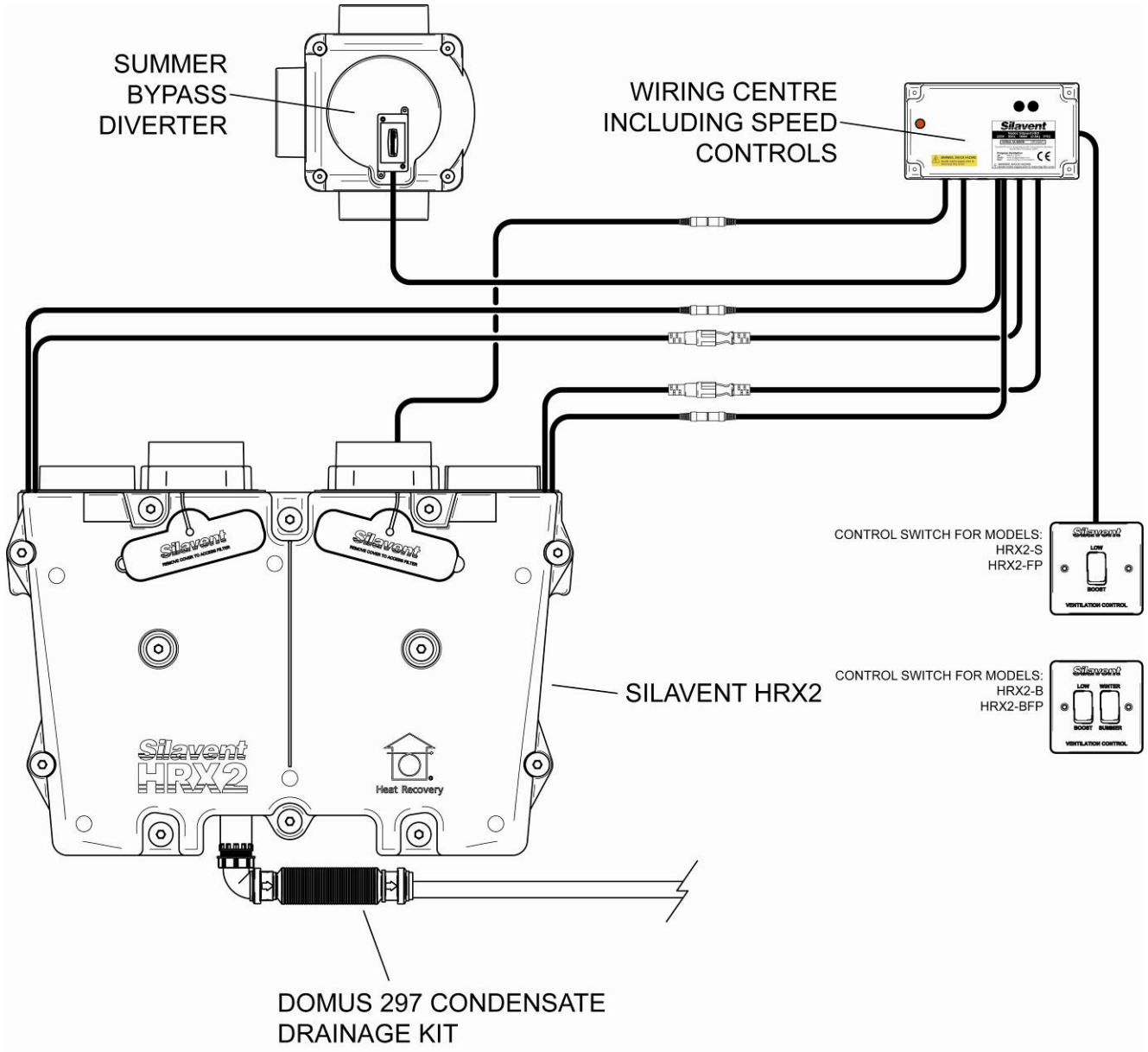

1.2 Physical specification

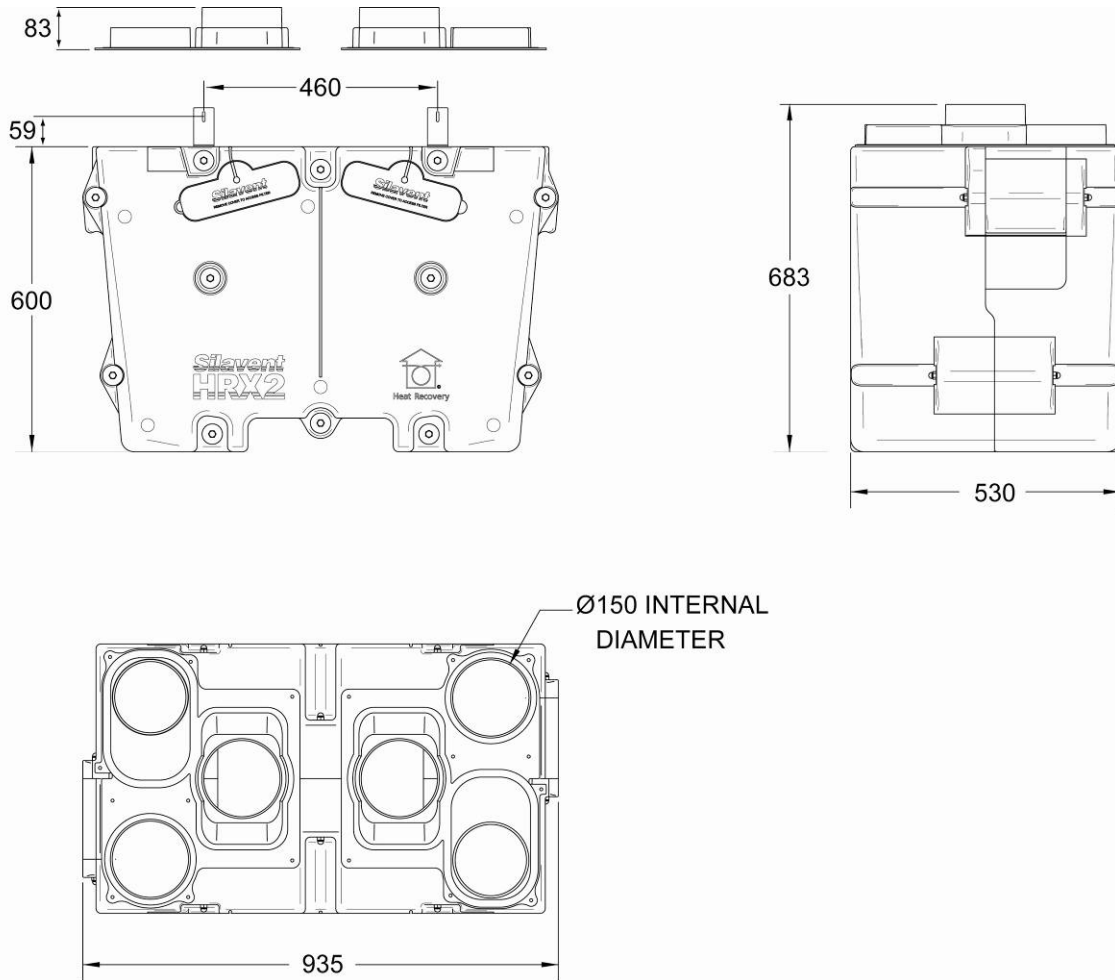

net weight 20kg

1.3 Optional main features

1.3.1 Summer bypass (HRX2-B, HRX2-BFP models)

The models listed above will be supplied with an additional Winter/Summer switch (see highlighted option boxes on the appliance cardboard cover). When the switch is set to summer, the fresh air is no longer pre-warmed by the heat in the outgoing stale air.

Important: when the switch is set to summer, both fans will **stop for 45 seconds** to allow the bypass diverter valve to open.



1.3.2 Frost protection (HRX2-FP, HRX2-BFP models)

The models listed above are supplied with an automatic frost protection system. During periods of very cold weather, the fresh air supply fan will automatically turn off to reduce the load on your heating system and avoid possible freezing of the heat exchanger. During these periods, the extract fan will speed up slightly to maintain an even air pressure. See also section 2.3.

2.0 Installation

2.1 Overview

- 2.1.1 The following instructions are intended to help prevent hazards. Installation should only be carried out by a qualified electrician and competent persons in clean, dry conditions where dust and humidity are at minimum levels.

Note: we advise installers to fix all mains, switch and sensor wiring (in accordance with the latest edition of the Wiring Regulations) prior to fixing the HRX2 unit in position. For convenience, buried cables for the wiring centre should terminate in a 2 gang metal box or dry-lining box. The wiring centre can be fixed directly onto the box using standard M3.5 screws (not supplied).

2.2 Preparation

- 2.2.1 When accepting delivery of the appliance, inspect for transit damage. If in doubt, call our Customer Services team on 08443 715523.
- 2.2.2 The HRX2 appliance and wiring centre can be fitted directly to a wall or suitable vertical or horizontal timber support (if loft mounting). **Important:** if mounting on a horizontal surface, make sure that adequate space/height has been considered for the condensate drain.
- 2.2.3 Ensure that the position chosen for the wiring centre is close enough to the HRX2 appliance so that there is no undue strain applied to the cables between the HRX2 appliance and the wiring centre. **Important:** these cables can not be lengthened or shortened.
- 2.2.4 Appropriate screw fixings to suit the support medium will need to be supplied by the installer. The support brackets for vertical mounting are pre-drilled to suit 2 x 4mm (No.8) round/pan-head screws.
- 2.2.5 Ensure that there is sufficient space for the wiring centre, condensation fittings and ductwork.
- 2.2.6 Ensure that there is sufficient space at the front of the appliance to access the filters and for carrying out any future maintenance on the appliance.
- 2.2.7 The HRX2 appliance can be mounted as a left-hand or right-hand installation, i.e. for convenience the two external duct connections can be either on the left or right-hand side. This feature can be extremely useful in smaller houses or apartments where there is no space to cross over ducts.
- 2.2.8 When viewed from above, the **two** duct configuration **options** are shown on the diagram below:

IMPORTANT: The configuration selected will determine the connection point for the condensate drain – see diagram below.

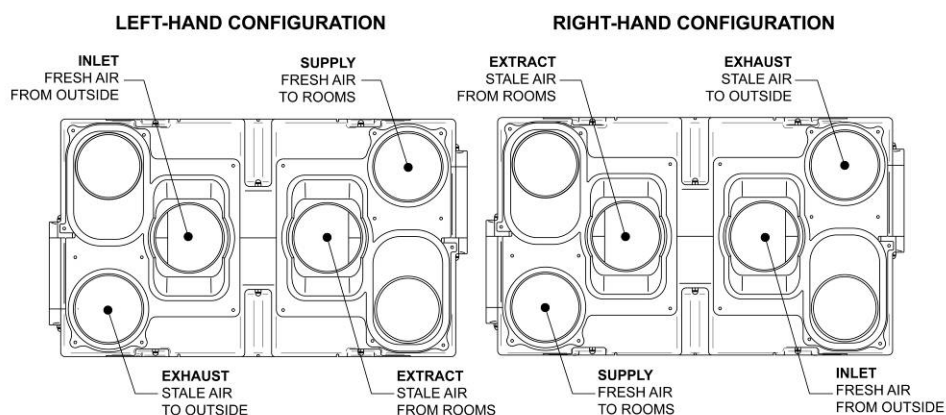

2.2.9 Using a hole-saw of minimum diameter 20mm (3/4") and maximum diameter 25mm (1"), remove the closed end of the condensate tray ensuring that any debris is entirely removed. For convenience a drill centring guide has been moulded into the tray – see diagram below.

LEFT-HAND CONFIGURATION

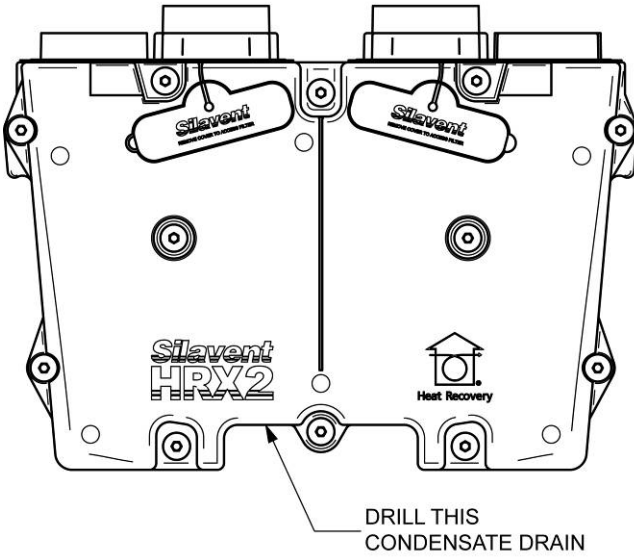

RIGHT-HAND CONFIGURATION

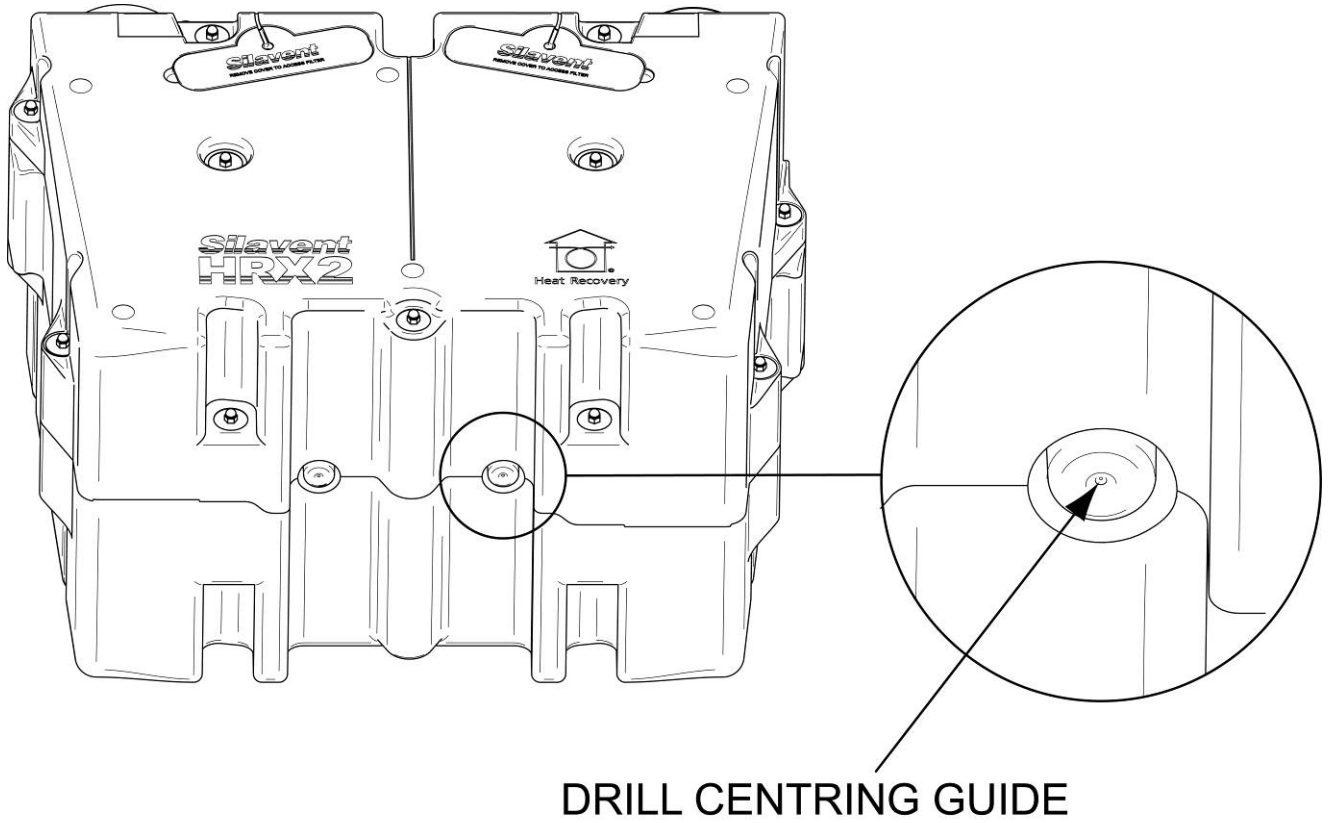
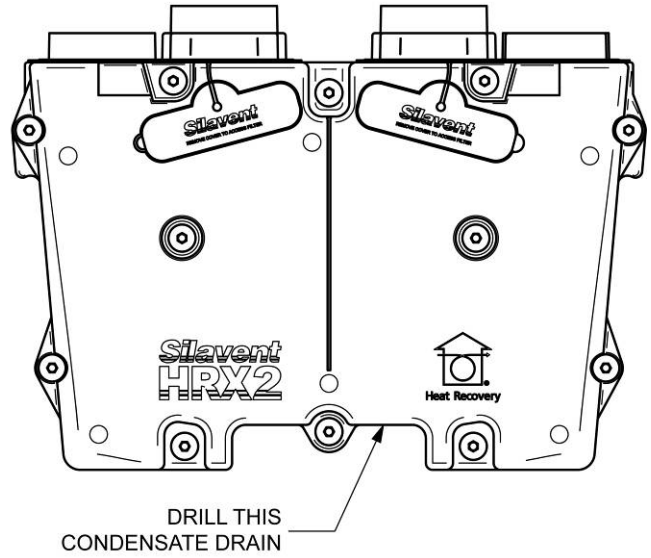

2.3 Installing the frost protection sensor (HRX2-FP, HRX2-BFP)

2.3.1 **Important:** This operation should only take place after the left or right-handed position of the appliance has been determined.

2.3.2 Referring to the diagram at 2.2.8;

2.3.3 Directly in line with the 'INLET FRESH AIR FROM OUTSIDE' socket and from the 'back' or 'mounting' side of the appliance, insert the frost sensor filter cover and gently push the cable into the groove running up the face of the main housing. Ensure that no undue stress is put on the cable.

2.3.4 See also 3.2 for wiring centre connections.

2.4 Wall/surface fitting the HRX2 appliance

2.4.1 Refer to the diagram on page 6 to determine where the extents of the appliance are in relation to the support brackets.

2.4.2 Rotate the two support brackets to a vertical position from their horizontal transit position.

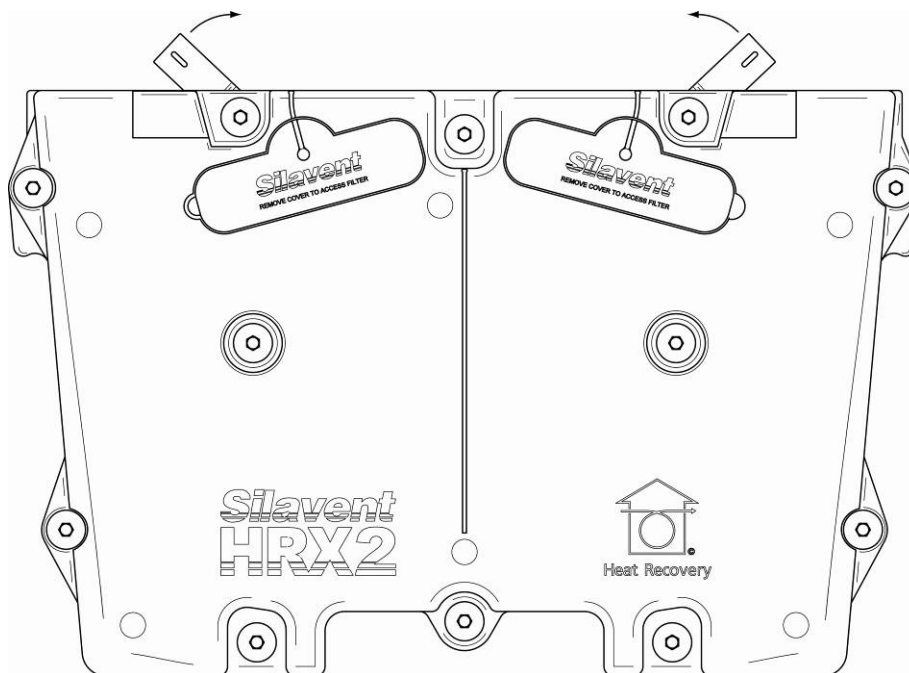

2.4.3 Using the support brackets as a template, mark the positions for the two fixings.

2.4.4 Using 2 x 4mm (No.8) round/pan-head screws and appropriate anchors (not supplied), secure the appliance.

2.4.5 Ensure that no cables are trapped behind the appliance and that the appliance is level front to back and side to side.

2.4.6 Attach the four black self-adhesive 'hook' pads, one onto each corner indentation of the main body. Attach the four white self-adhesive 'loop' pads, one to each corner of the cardboard 'householder-instruction' cover. Carefully fit the 'householder-instruction' cover by pressing to engage the 'hook and loop' pads.

2.5 Fitting the bypass valve

2.5.1 Referring to the diagram below; the heat exchanger bypass mechanism is operated in the same way as a motorised 3-port valve, diverting the warm, stale exhaust air around the heat exchanger when 'SUMMER' operation is selected.

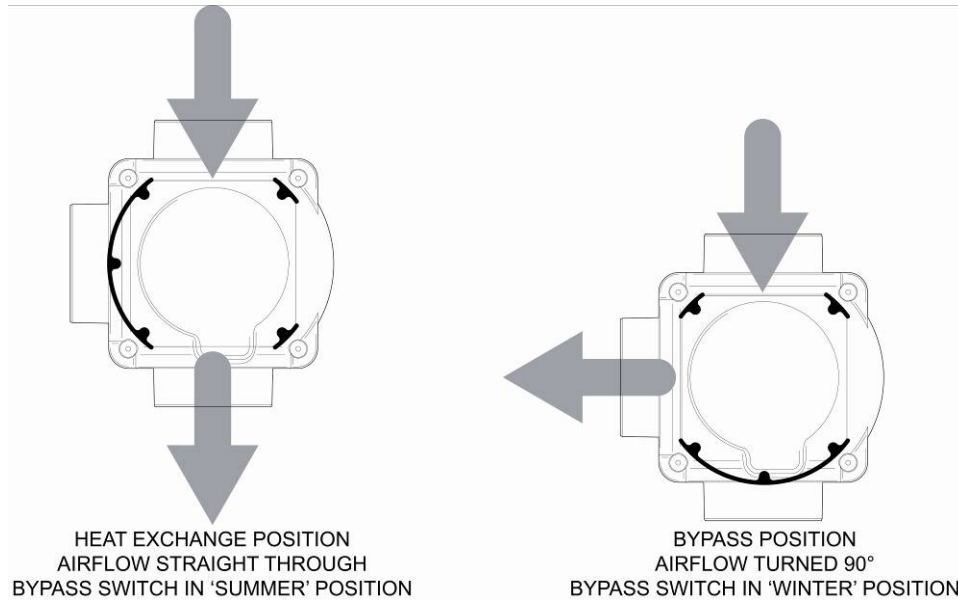

2.5.2 Select the appropriate air path and fit the two duct connection plates to suit using the screws provided.

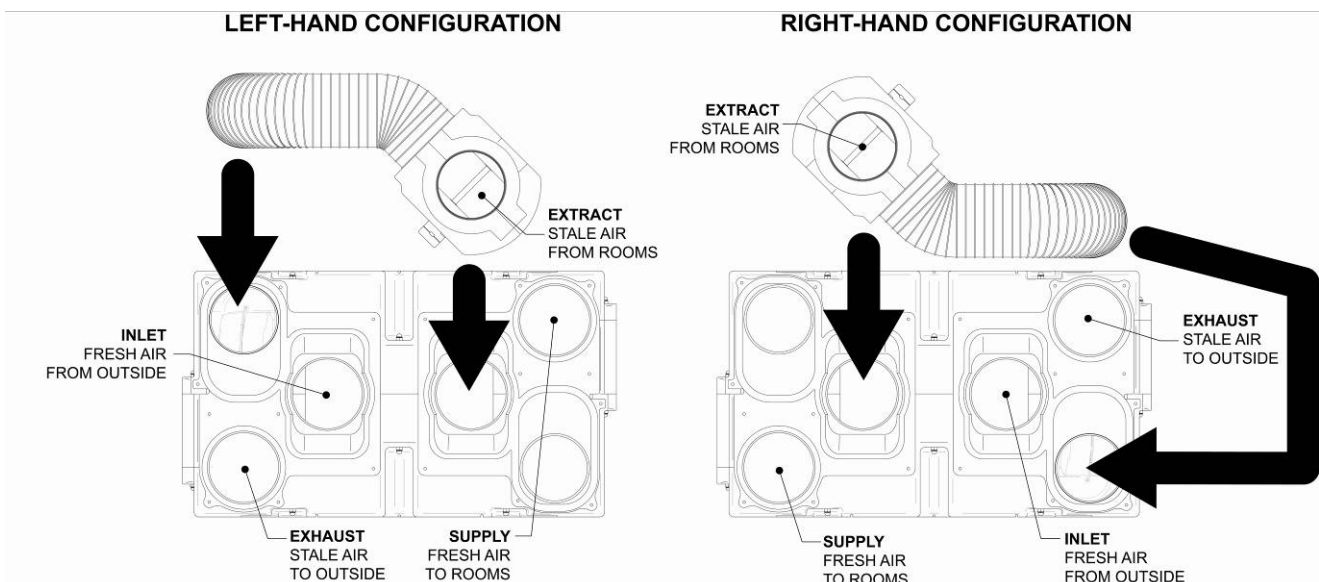

2.5.3 The bypass valve can be fitted directly onto the appliance using the flexible hose and hose clamps provided or mounted remotely using extra duct. Ensure that the bypass valve cable will reach the wiring centre.

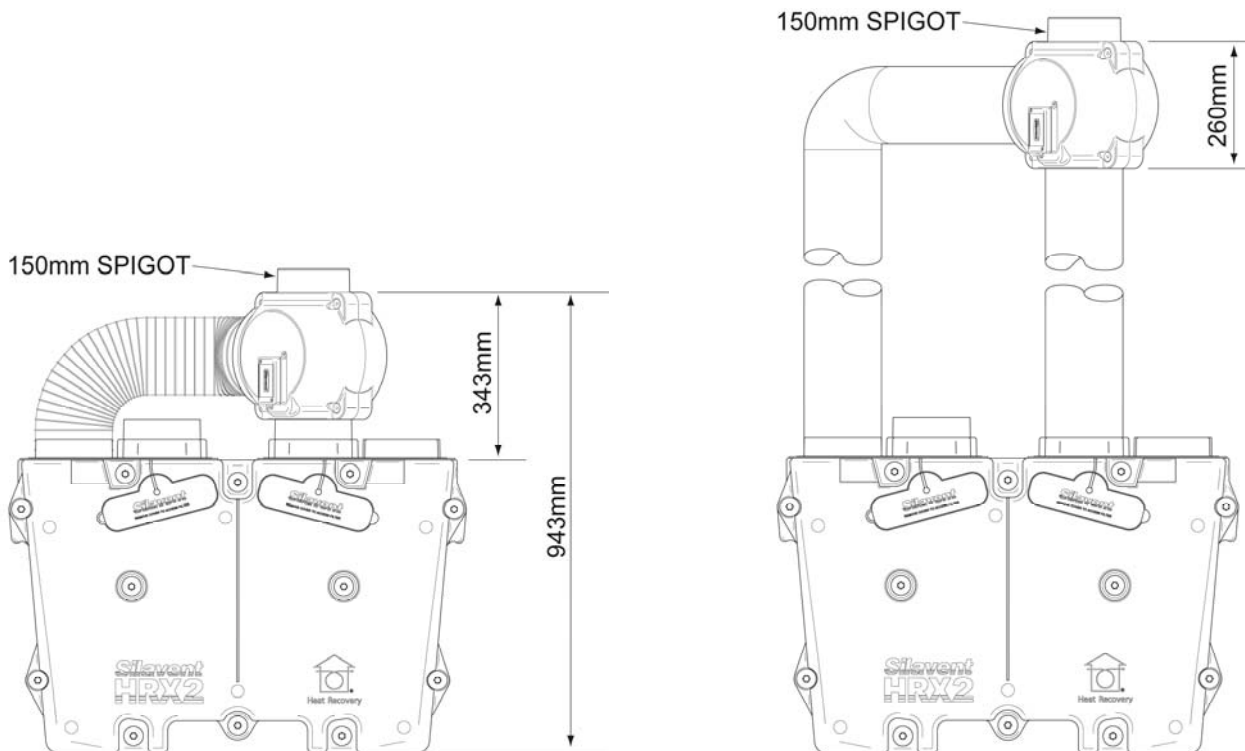

2.6 Fitting the wiring centre

- 2.6.1 Remove the cover of the wiring centre by removing the four retaining screws while taking care not to dislodge any of the cables.
- 2.6.2 Carefully remove sufficient knock-out panels in the mounting plate to provide access for the mains supply, switch and external sensor cables.

Either;

- 2.6.3 Pass the cables through the knock-outs and push the mounting plate firmly against the mounting surface. Using 2 x M3.5 electrical screws (not supplied) through the upper fixing holes, attach the mounting plate to the 2 gang metal box or dry-lin box already installed (not supplied).

Or;

- 2.6.4 Pass the cables through the knock-outs and push the mounting plate firmly against the mounting surface. Using the mounting plate as a template, mark the positions for the two lower fixing holes. Using 2 x 3mm (No.6) round or pan head screws and appropriate anchors (not supplied), secure the mounting plate.
- 2.6.5 Make the wiring connections – see section 3.0
- 2.6.6 Refit the cover.

2.7 Fitting the Domus 297 condensate drain kit

- 2.7.1 Using a small amount of solvent weld suitable for ABS pipe fittings (not supplied), attach the threaded socket to the selected condensate outlet spigot (see no 2.1.9). **Important:** follow the health and safety and user instructions supplied with the solvent weld. This is particularly important when working in confined spaces.

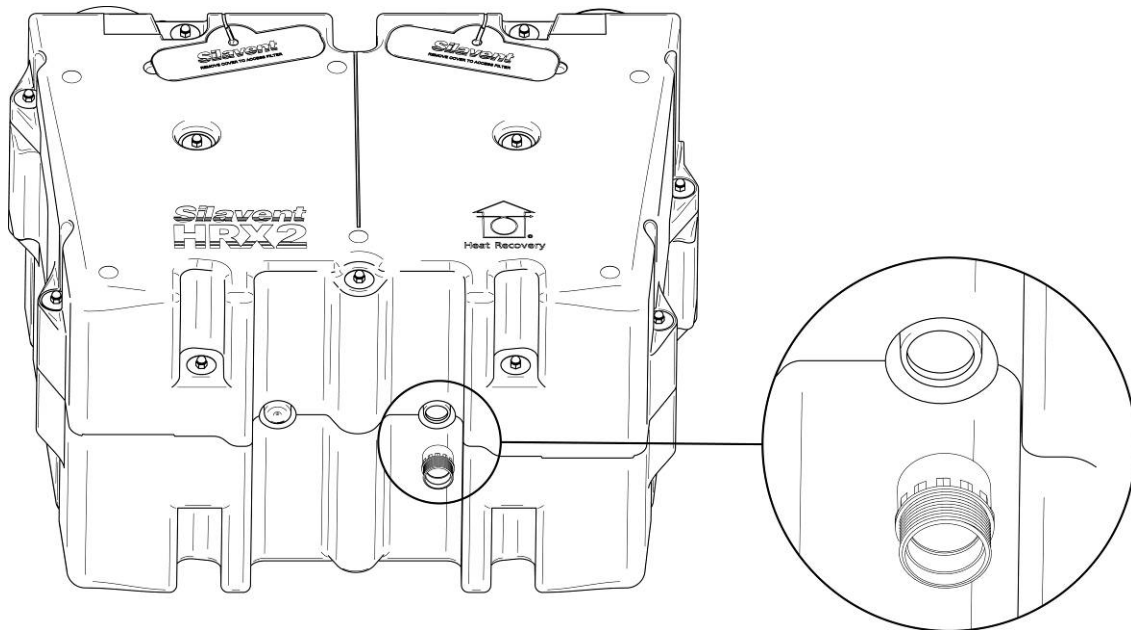

- 2.7.2 When the threaded socket is secure, fit and hand-tighten the threaded elbow, making sure that the rubber seal washer is seated correctly. Gently push the waterless trap onto the elbow stem. **Important:** check that the arrows printed on the trap point away from the HRX2 appliance (in the direction of flow) and prior to fitting, ensure that the waterless trap operates correctly by running a trickle of water from a tap through the trap in the direction of the arrows.
- 2.7.3 Using the remainder of the kit items complete the condensate drain-system to suit the dwelling layout. **Important:** the drain must incorporate a continuous fall of approximately 0.5° (9mm in every 1000mm) to the nearest waste water network.
- 2.7.4 The condensate drain system should be adequately supported and suitably insulated if it passes through unheated spaces and voids (e.g. loft spaces) to prevent freezing.

2.8 Ducting guidelines

- 2.8.1 Please refer to the design drawings for the proposed ducting layout.
- 2.8.2 Four Ø150mm diameter sockets are provided for connecting the ducting. Rigid ductwork should be securely connected to the sockets using **Domus DDSEAL** acrylic sealant; failure to do this will cause unnecessary air leakage and impair performance. Ducting must be connected to all four sockets according to left or right-hand configuration (see 2.2.7).
- 2.8.3 Alternatively, heavy duty flexible hose connection kit, **HRX2-CK1**, is available to make soft/offset connections between the HRX2 and the rigid duct system.
- 2.8.4 Where ducting passes through unheated areas and voids (e.g. loft spaces) it must be insulated using **Domus Thermal** duct insulation in order to comply with The Building Regulations. Additionally, both ducts connecting the HRX2 to outside must be insulated when passing through heated areas to avoid condensation forming on the outside of the ducts.

- 2.8.5 Alternative proprietary duct insulation may be used provided it complies with the 2010 Domestic Ventilation Compliance Guide.
- 2.8.6 When passing through a fire-stopping wall or fire-compartment wall, **Domus FireBrake** intumescent duct connectors should be used in order to comply with The Building Regulations.
- 2.8.7 Alternative proprietary fire-stopping methods may be employed provided they comply with Approved Document B of The Building Regulations.
- 2.8.8 Rigid ducting – install using the least number of fittings to minimise resistance to airflow. **Important:** Reducing the duct size below Ø150mm diameter or 220mm x 90mm rectangular may have an adverse effect on airflow performance. All duct runs should be as short and as straight as possible for maximum performance.
- 2.8.9 Flexible ducting – ensure flexible ducting lengths are kept to a minimum and ducting is pulled taut so that it is smooth and straight. Where bends are necessary and where ducting runs in restricted areas, ensure that the ducting is not crushed. Mechanically fix flexible ducts using **Domus 125-6** hose clips and tape seal using **Domus 50TP45** duct tape or any good quality proprietary duct tape for added air-tightness.
- 2.8.10 The fresh supply air must be drawn in from the exterior of the property. If drawn through a wall, a **Domus 905** airbrick or **Domus 6904** fixed louvred grille should be fitted. If drawn in through the roof a **Domus 4411** universal roof terminal should be fitted or a proprietary roof terminal designed for mechanical ventilation with a free area of at least 15175mm².
- 2.8.11 The stale extract air must be expelled to the exterior of the property. If expelled through a wall, a **Domus 905** airbrick or **Domus 6904** fixed louvred grille should be fitted. If expelled through the roof a **Domus 4411** universal roof terminal should be fitted or a proprietary roof terminal designed for mechanical ventilation with a free area of at least 15175mm².
- 2.8.12 It is recommended that the fresh supply and stale exhaust external inlets and outlets should be fitted at least 2m apart to avoid recirculation of stale exhaust air.
- 2.8.13 Further details regarding installation can be found in the 2010 Domestic Ventilation Compliance Guide.

3.0 Electrical

3.1 Overview

3.1.1 **WARNING: This appliance must be earthed.**

3.1.2 **Important: All wiring must conform to the prevailing national regulations, for example the latest edition of BS7671: IEE Wiring Regulations.**

3.1.3 **Important: The electrical installation must be carried out by a qualified electrician.**

3.1.4 This appliance is suitable for 230V 50Hz single phase supply only, fused at 3 Amps.

3.1.5 A double-pole switch having a minimum contact separation of 3mm must be used to provide isolation for the appliance.

3.1.6 Refer to page 14 for HRX2-S, wiring diagram, page 15 for HRX2-B, wiring diagram, page 16 for HRX2-FP wiring diagram and page 17 for HRX2-BFP wiring diagram.

3.1.7 Supplementary sensor diagrams are shown on page 18.

3.1.8 External wiring (1.5mm² max.) and isolators to be supplied by others.

3.2 Frost protection only, wiring-centre fan connections (HRX2-FP, HRX2-BFP)

3.2.1 **Important: the fan selected as SUPPLY FRESH AIR TO ROOMS must be connected as shown in the diagram below.**

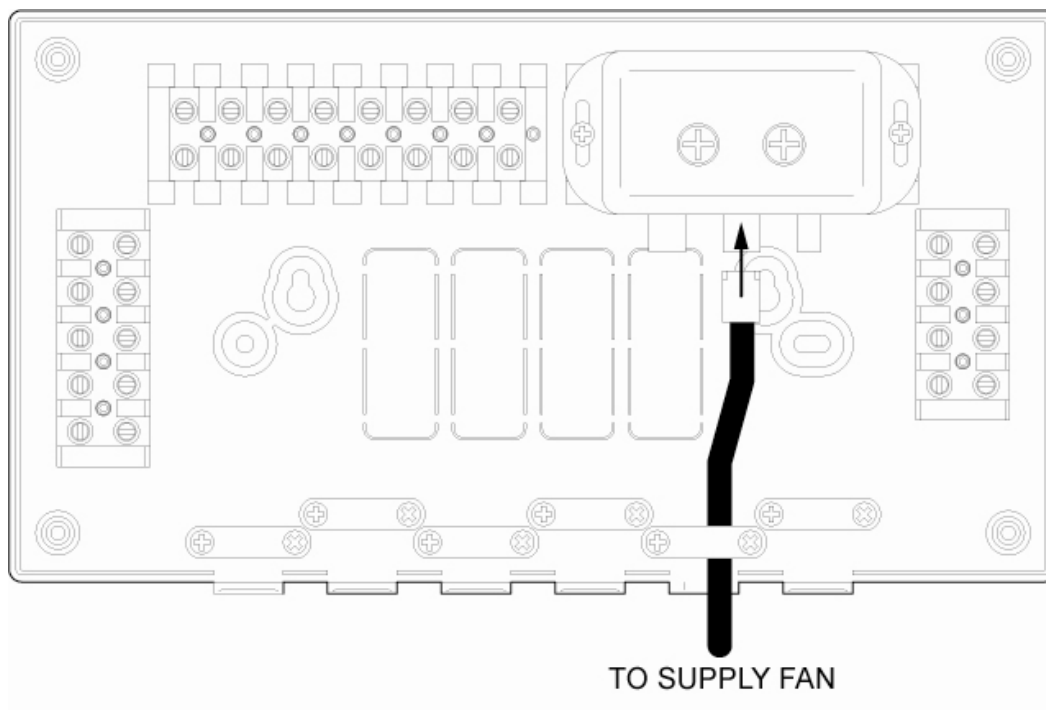

4.0 Commissioning

4.1.1 Overview

4.1.2 When the wiring connections have been checked, and it is safe to do so, switch on the mains supply and check that the system is operating correctly. The appliance should switch between low and boost speeds using the manual boost switch (see 1.1.2).

4.1.3 Airflow rates will need to be set at each room's air valve in accordance with the 2010 Domestic Ventilation Compliance Guide to balance the system. Airflow measurements should be performed using a calibrated airflow measuring device and the results recorded in litres per second (l/s) onto the Inspection Checklist and Airflow Measurement Test Sheet contained within the 2010 Domestic Ventilation Compliance Guide. The most common method uses a vane anemometer, or similar, placed in a hood which completely covers the air valve to measure the extract or supply airflow rate. The instrument should be calibrated annually by returning the instrument to a UKAS accredited calibration centre and be capable of achieving an accuracy of $\pm 5\%$.

4.1.4 Each room airflow rate will need to be recorded on the Inspection Checklist and Airflow Measurement Test Sheet. A completed copy must accompany these instructions and be handed over to the dwelling owner upon completion of the installation.

4.2 System balancing

- Fully open all of the air valves
- Switch the system to **boost**
- Close all internal and external doors and windows
- Measure the total air volume of the **extract** valves (wet rooms)
- Remove the rubber tamper-deterrent cap and using a small screwdriver, adjust the 'boost' control on the wiring centre to achieve the total design extract rate
- Adjust individual room air valves to achieve the individual room design extract rates
- Switch the system to **low**
- Measure the total air volume of the **supply** valves (habitable rooms)
- Remove the rubber tamper-deterrent cap and using a small screwdriver, adjust the 'low' control on the wiring centre to achieve the total design supply rate
- Adjust individual room air valves to achieve the individual room design supply rates
- Using the lock nuts fitted to the air valves, lock in position
- Refit the rubber tamper-deterrent caps to the lid of the wiring centre

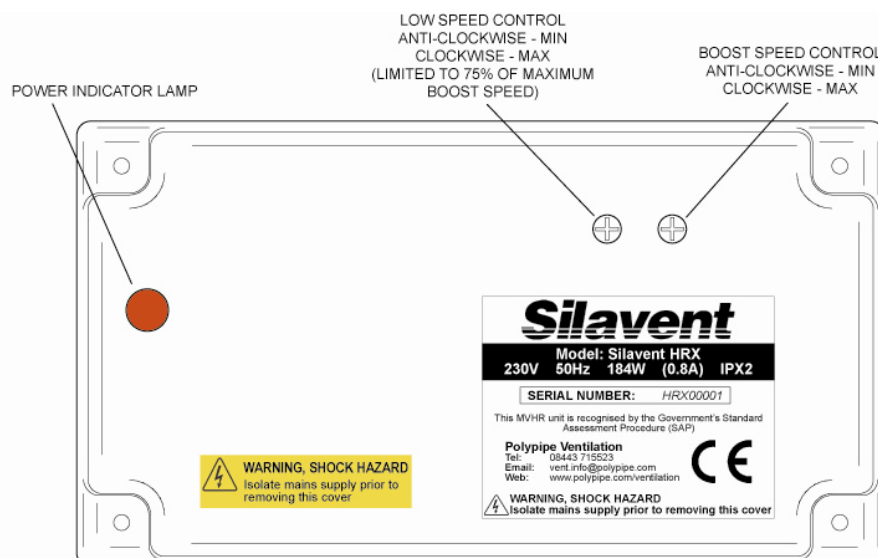

HRX2-S wiring diagram

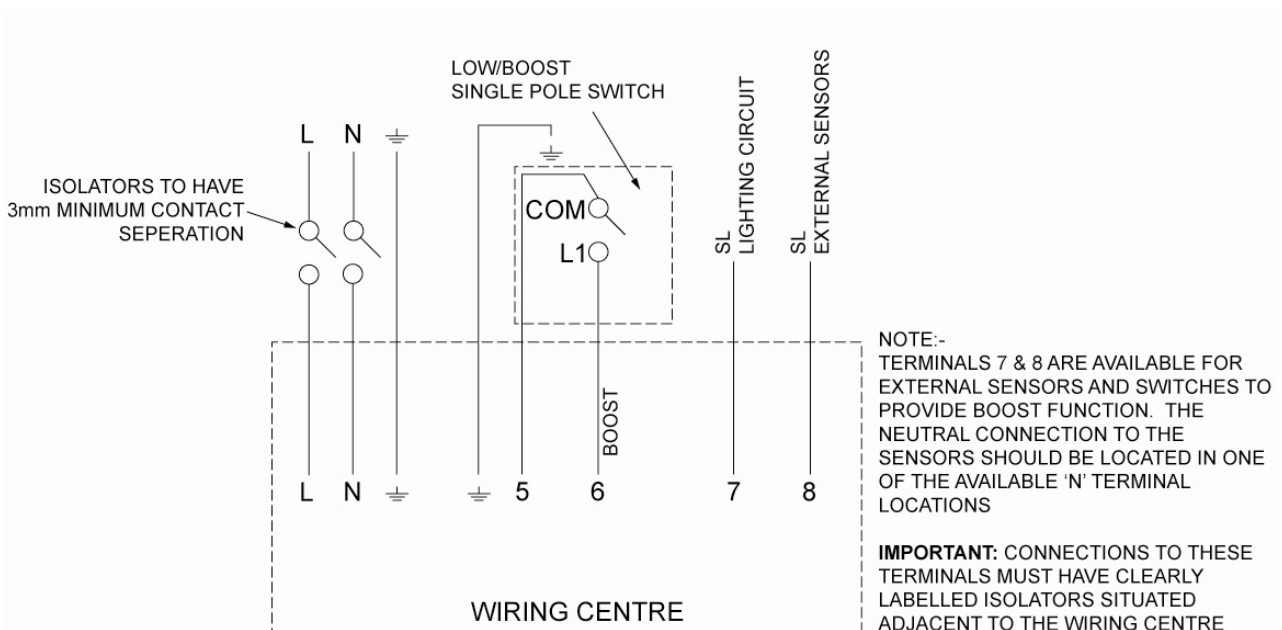
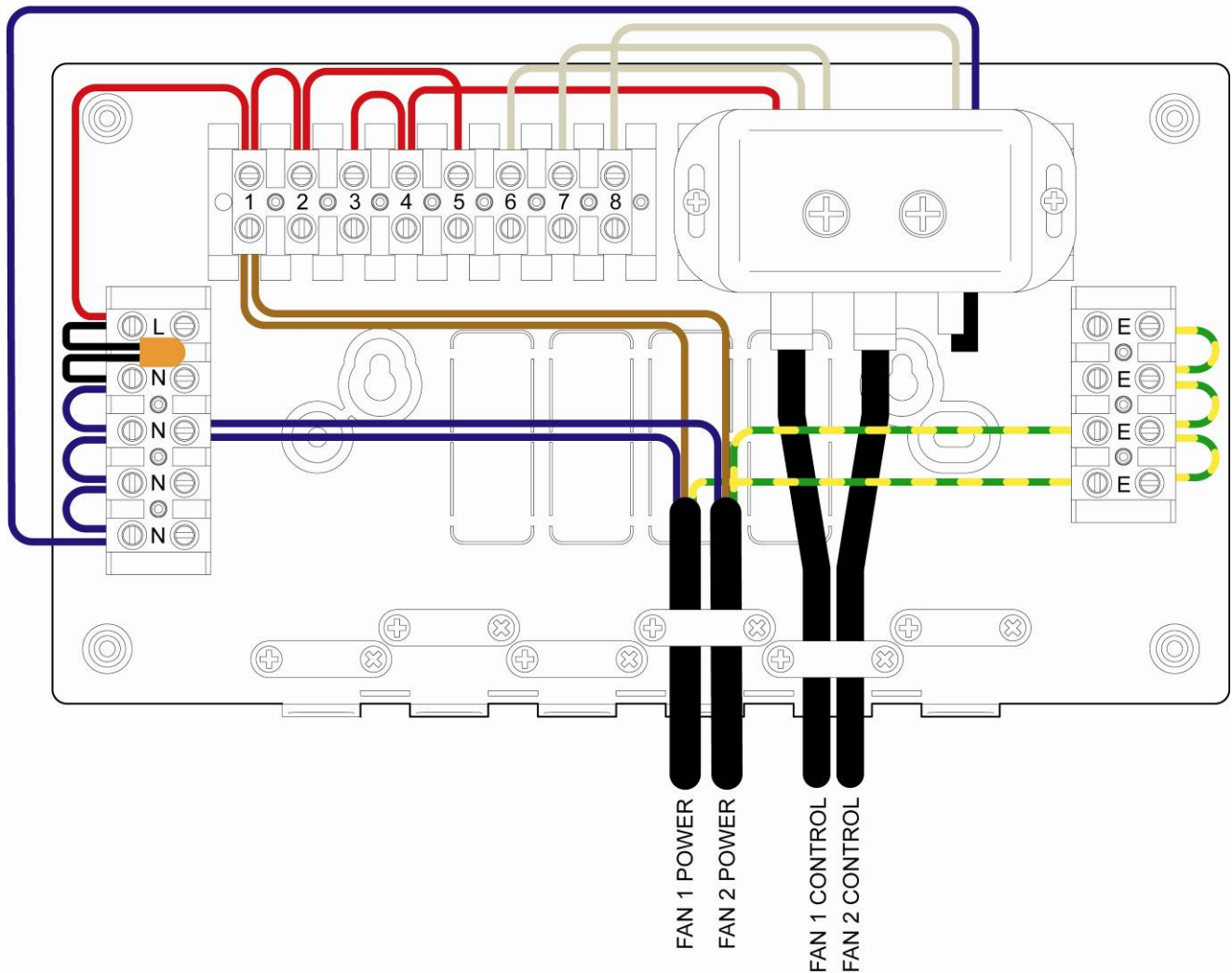

HRX2-B wiring diagram

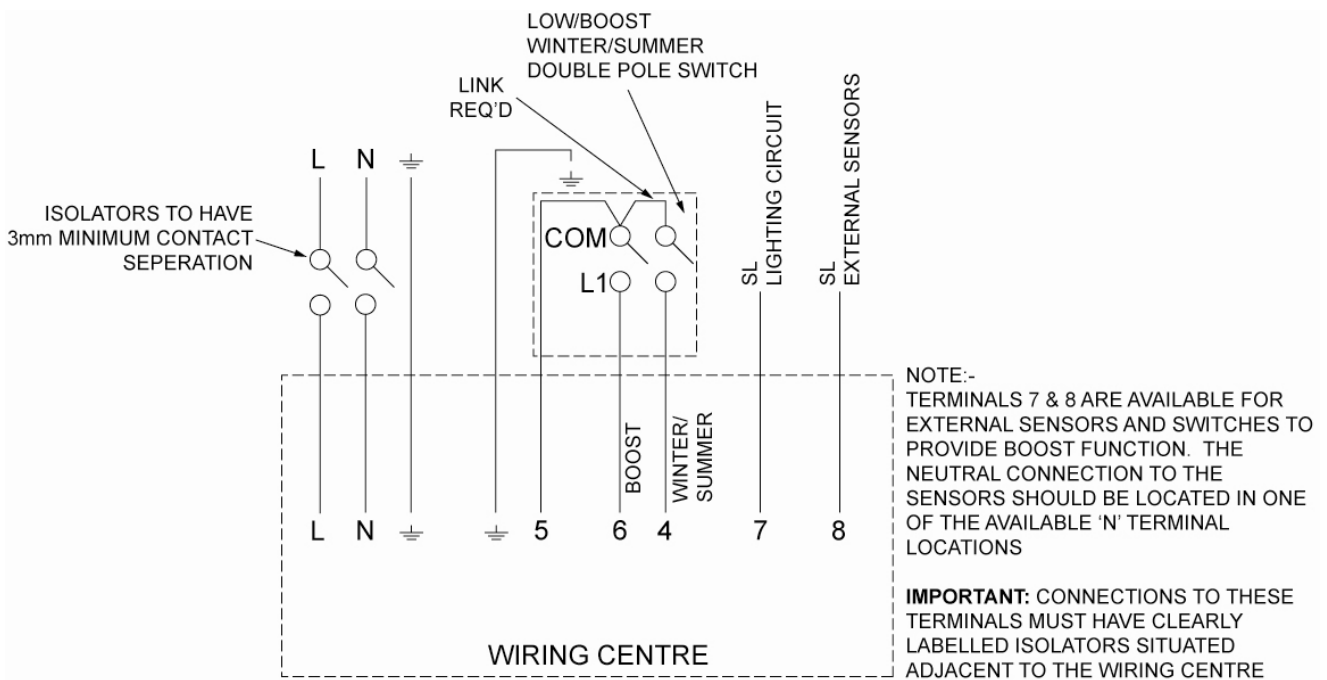
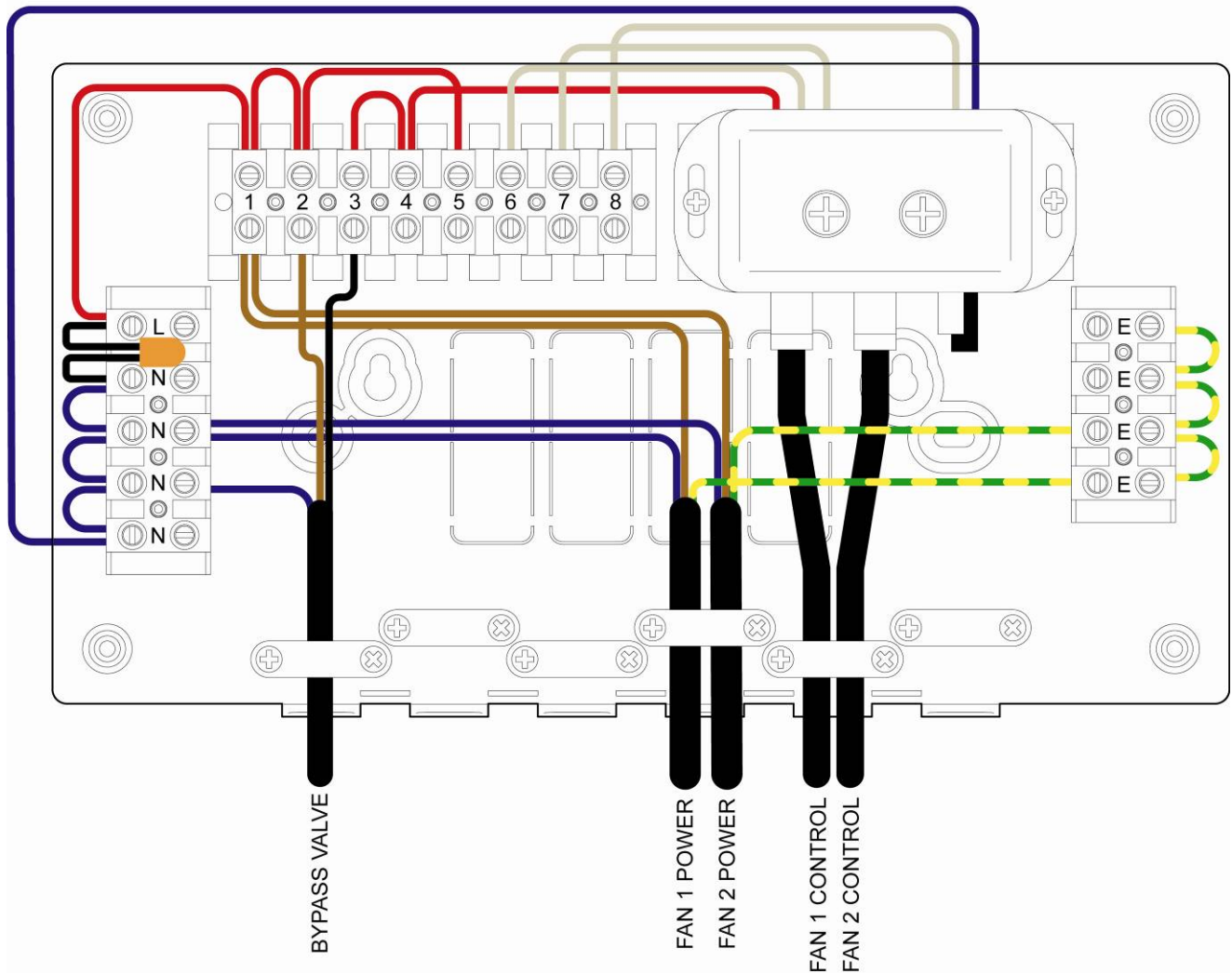

HRX2-FP wiring diagram

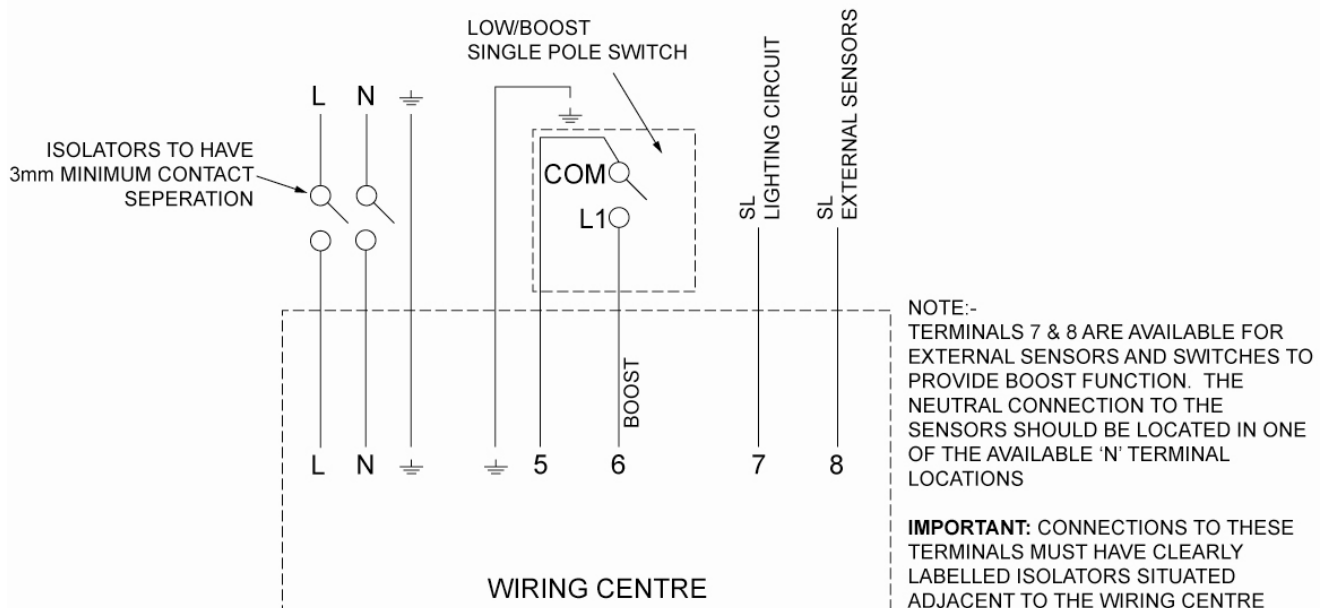
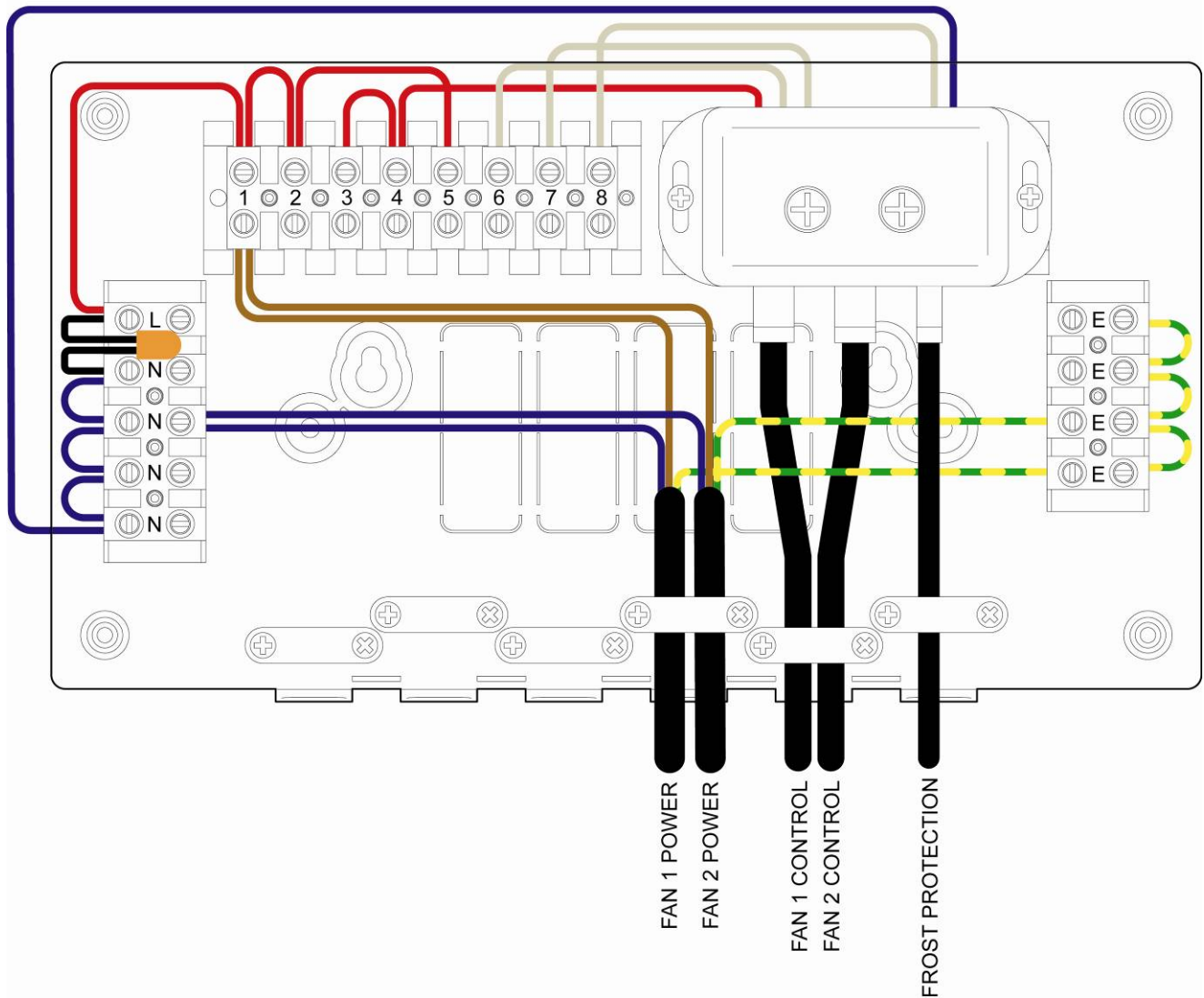

HRX2-BFP wiring diagram

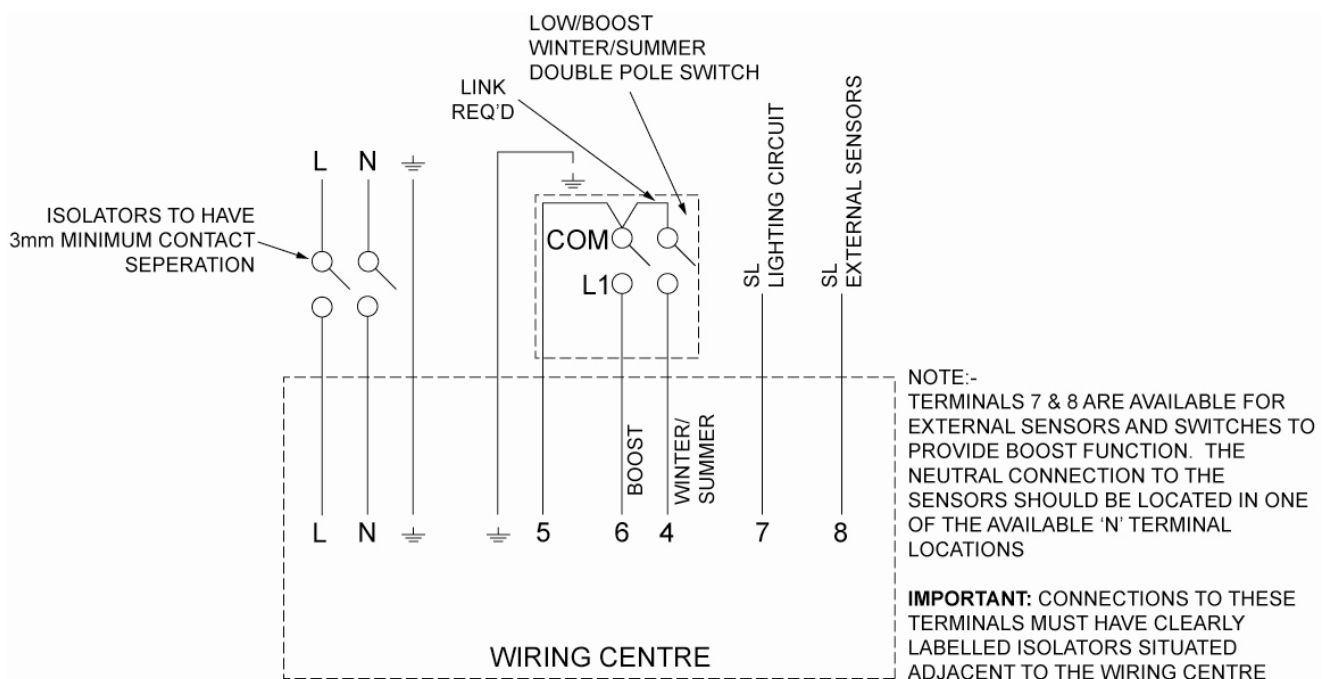
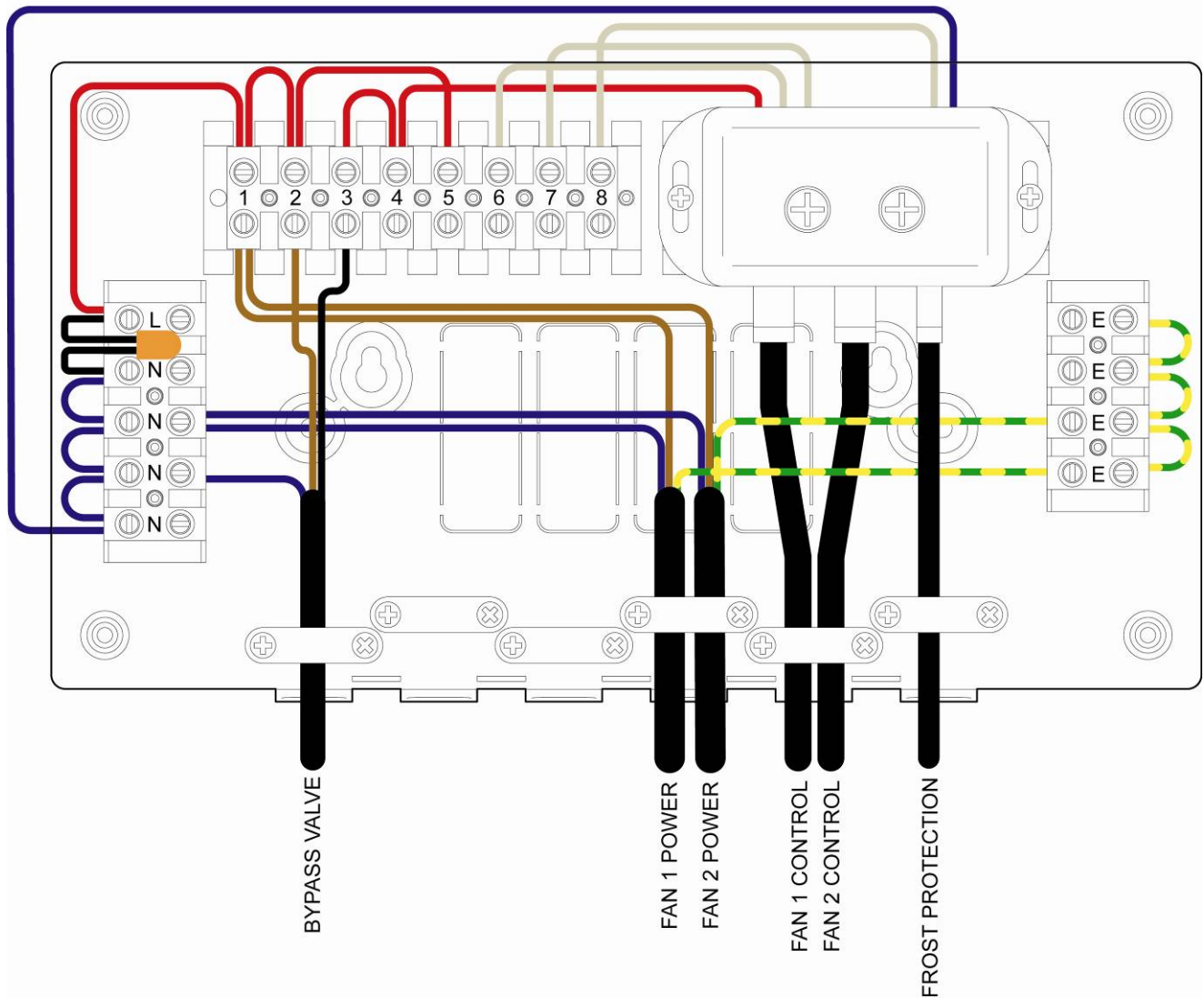

ANC108A, ANC802A, ANC846A, ANC808A, ANC813A and ELE150R wiring diagrams

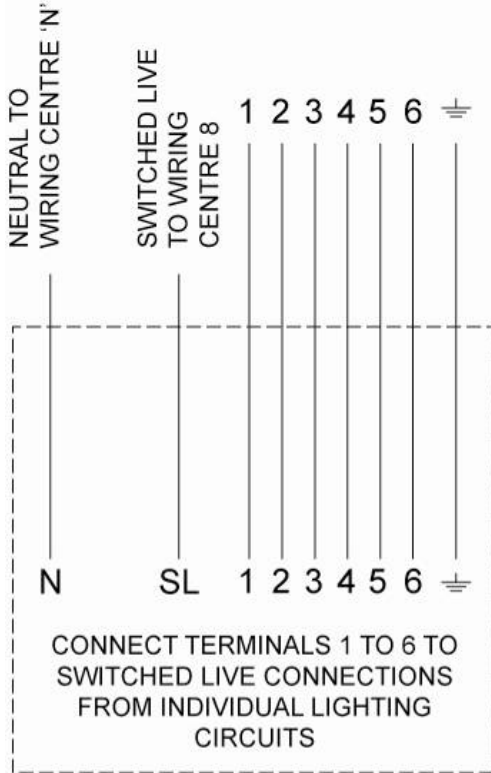

ELE150R – SWITCHED LIVE EXTENSION BOARD

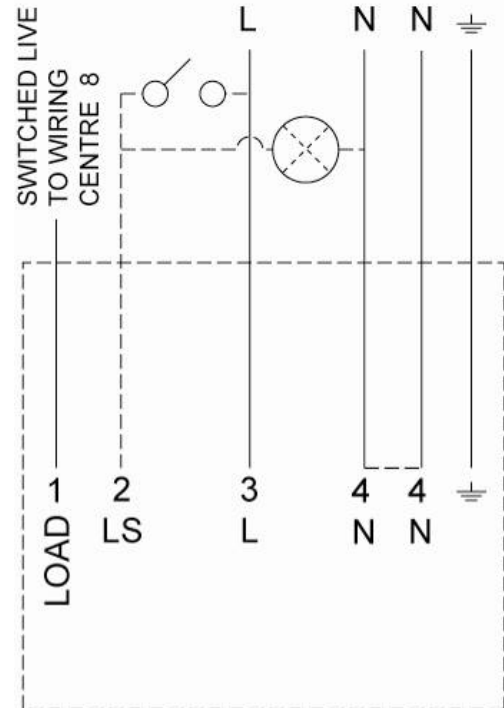

ANC108A – OVERRUN TIMER

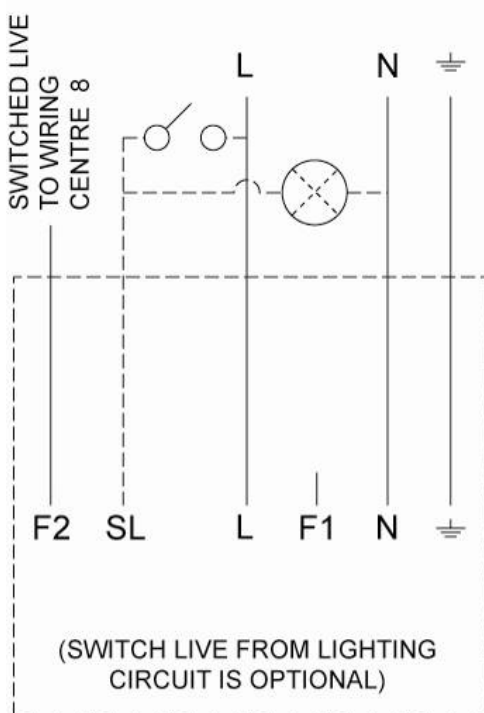

ANC802 – HUMIDISTAT WITH TIMER, ANC846A – HUMIDISTAT WITH TIMER AND REMOTE SENSOR
ANC808A – HUMIDISTAT WITH PULLCORD

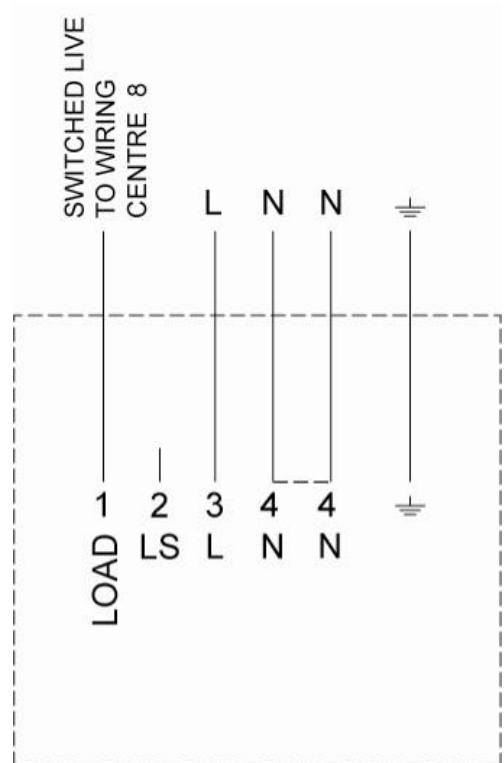

ANC813A – PIR WITH OVERRUN TIMER

NOTE:-

TERMINALS 7 & 8 IN THE WIRING CENTRE ARE AVAILABLE FOR EXTERNAL SENSORS AND SWITCHES TO PROVIDE BOOST FUNCTION

IMPORTANT: CONNECTIONS TO THESE TERMINALS MUST HAVE CLEARLY LABELLED ISOLATORS SITUATED ADJACENT TO THE WIRING CENTRE

5.0 Maintenance

5.1 Routine maintenance

- 5.1.2 The appliance G3/EU3 filters should be cleaned on a regular basis, the exact frequency will be determined by individual living conditions.
- 5.1.3 Before cleaning the filters, turn off the appliance at the isolator switch.
- 5.1.4 To remove the two filters, pull out the two caps from the front of the appliance and gently slide out the filters in their carrier frames.
- 5.1.5 Lightly vacuum the filters to remove surface debris and then gently wash through in warm soapy water. Ensure that the filters are completely dry before refitting. **Important:** do not dry on a radiator or use excessive heat as this will distort the carrier frames.

6.0 Warranty

LIMITED TWO YEAR WARRANTY

In the event that any problem or fault develops with the product due to faulty materials or workmanship during the two year period beginning on the date on which you purchased the product then subject to the various limitations and exclusions as detailed below, Polypipe will as soon as reasonably possible either repair or replace the product during its usual working hours or, at Polypipe's discretion, provide you with a refund of the purchase price which you paid for the product.

If you need to make a claim under this warranty then please contact Polypipe using one of the following methods:

Polypipe Ventilation
Sandall Stones Road
Kirk Sandall Industrial Estate
Kirk Sandall, Doncaster
DN3 1QR, UK

Tel: 08443 715523
Fax: 08443 715524
International Tel: +44 (0)1302 348878
International Fax: +44 (0)1302 348879

Email: vent.info@polypipe.com

The above warranty does not apply to nor cover the repair of any problem or fault with the product which arises as a result of: (a) failure to install, operate, maintain and/or repair the product or any associated parts and components (including any ducting) using reasonable skill and care and in accordance with the instructions provided with it (unless the original installation, maintenance or repair which gave rise to the problem or fault was carried out by or on the behalf of Polypipe in which case this exclusion will not apply); (b) use of the product for any purposes other than those for which it is designed; (c) modifications made to the product by anyone other than Polypipe or its approved contractors; (d) deliberate damage; and/or (e) damage caused by fire, flood or other water damage, explosions, rust or corrosion. Polypipe may carry out the repair or replacement of the product itself or using an approved sub-contractor but will always remain liable to you for the acts or omissions of any such sub-contractor as if those were the acts or omissions of Polypipe itself.

Where you have purchased the product acting in your capacity as a consumer then the above warranty is offered by Polypipe in addition to and is not intended to affect or lessen those statutory rights which you became entitled to as a consumer when you purchased the product. In the UK you can find out more about your rights as a consumer by visiting the website of the Citizen's Advice Bureau

(http://www.adviceguide.org.uk/england/consumer_e.htm).

In addition to this two year warranty Polypipe also offers **extended warranty protection** for this product for consumers based in the UK subject to additional terms and conditions. You can find out more about this extended warranty cover and purchase by contacting Polypipe using one of the above methods.

Installer contact details:

Company name:
Contact name:
Tel:
Email:

Polypipe Ventilation
Sandall Stones Road
Kirk Sandall Industrial Estate
Kirk Sandall
Doncaster
DN3 1QR
UK

Tel: +44 (0)8443 715523
Fax: +44 (0)8443 715524

International Tel: +44 (0)1302 348878
International Fax: +44 (0)1302 348879

Email: vent.info@polypipe.com
Web: www.polypipe.com/ventilation

Have you considered an extended warranty package, for extra peace of mind?

Polypipe offer extended warranty options.

Please refer to page 22 for further information or call our Customer Service Department on 08443 715523.

E&OE