

# RHP 1500 U C5

Nominal air flow, m <sup>3</sup> /h	1400
Nominal air flow, l/s	389
Panel thickness, mm	50
Unit weight, kg	260
Supply voltage, V	3~400
Maximal operating current, A	21,9
Filters dimensions B×H×L, mm	750×400×46
Electric power input of the fan drive at maximum flow rate, W	263
Electric air heater capacity, kW / Δt, °C	2/4
Refrigerant R134 A, kg	3,1
Maintenance space, mm	800
Control system	C5



## Acoustic data

A-weighted sound power level  $L_{WA}$ , dB(A)  
at reference flow rate

Supply inlet	59
Supply outlet	73
Exhaust inlet	60
Exhaust outlet	61
Casing	54

A-weighted sound pressure level  $L_{pA}$ , dB(A)

10 m<sup>2</sup> normally isolated room, distance from casing – 3 m.

Surroundings	44
--------------	----

## Performance

Filter M5, rotary heat exchanger L, heat pump system and electric air heater.

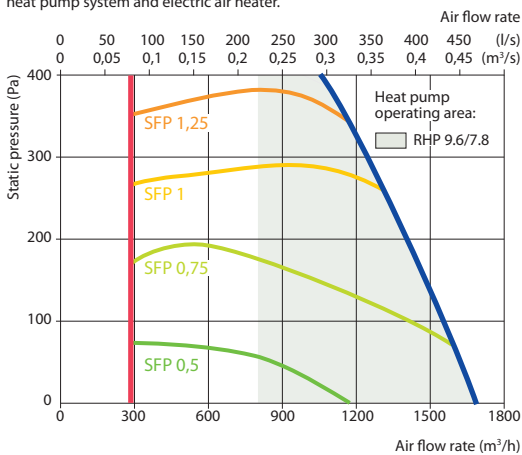

## Temperature efficiency

Outside temperature, °C	Winter					Summer		
	-23	-15	-10	-5	0	25	30	35
After heat exchanger, °C	14,0	15,4	16,3	17,2	18,1	22,5	23,4	24,3

indoor +22°C, 20 % RH.

Shown as right (R1)

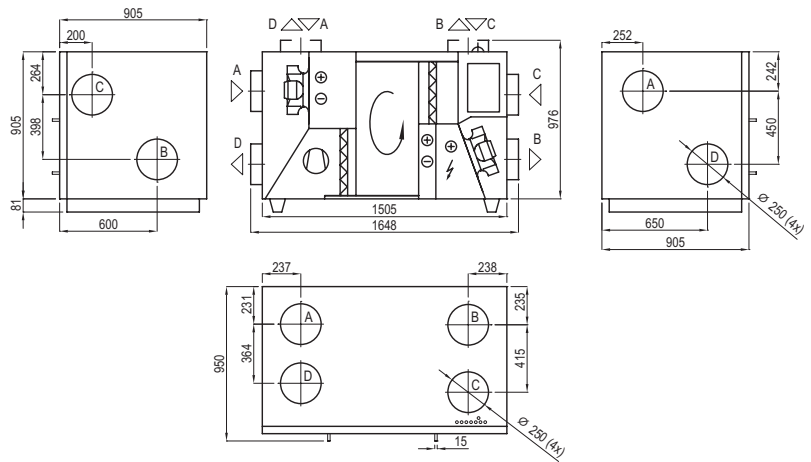

Shown as left (L1)

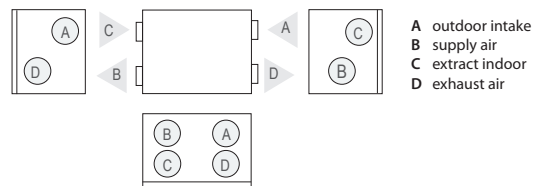

## Accessories

Closing damper	AGUJ-M-250+LF24/LM24
Silencer	A/D AGS-250-100-600-M
	B/C AGS-250-100-900-M

**Heating mode**

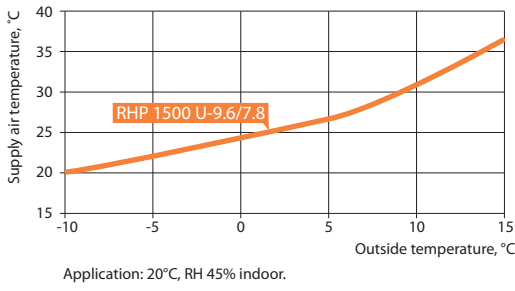

**Cooling mode**

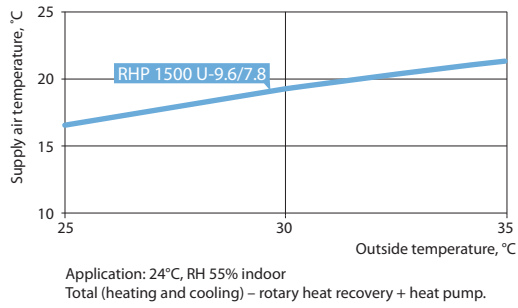

**Heat pump parameters**

	RHP 1500 U 9.6/7.8				
	Heating			Cooling	
Outdoor temperature, °C	7	2	-7	35	27
Outdoor air related humidity, %	86	84	74	40	45
Indoor air temperature, °C	20	20	20	27	21
Indoor air related humidity, %	50	50	45	40	50
Supply air temperature, °C	27	25	21,5	19,6	13,7
Heat pump heating/cooling power, kW	4,71	4,3	3,57	4,51	4,7
Heat pump heating/cooling power consumption, kW	1,14	0,98	0,99	1,34	1,16
System SCOP <sup>1,2,3</sup> , Average climate / System SEER <sup>1,2,3</sup>	10,6			3,9	
COP/EER	4,01	4,37	3,52	3,67	3,94

<sup>1</sup> Rotary heat exchanger wave size "L"  
<sup>2</sup> Rotary heat exchanger + heat pump  
<sup>3</sup> According to EN 14825 standard